



SmartGen
ideas for power

HMC9000
DIESEL ENGINE CONTROLLER
(With J1939 Interface)
USER MANUAL



ZHENGZHOU SMARTGEN TECHNOLOGY CO.,LTD.



Chinese trademark

SmartGen English trademark

SmartGen – make your generator *smart*

SMARTGEN(ZHENGZHOU) TECHNOLOGY CO., LTD.

No.28 Jinsuo Road, Zhengzhou, Henan Province, China

Tel: +86-371-67988888/67981888/67992951

+86-371-67981000(overseas)

Fax: +86-371-67992952

Email: sales@smartgen.cn

**Web: www.smartgen.com.cn
www.smartgen.cn**



All rights reserved. No part of this publication may be reproduced in any material form (including photocopying or storing in any medium by electronic means or other) without the written permission of the copyright holder.

Smartgen Technology reserves the right to change the contents of this document without prior notice.

Software Version

Date	Version	Content
2013-11-05	1.0	Original release.
2014-06-10	1.1	HMC9000E "Module Comparison" is added.
2015-03-25	1.2	Modify case dimension and alarm latch function. Add data display, alarm and settings of AIN16-C, AIN16-PT, AIN16-M01 modules.
2015-12-25	1.3	Add PLC functions and modify alarm display.
2021-04-01	1.4	Modify the case dimension and factory default password.

Clarification of notation used within this publication.

Sign	Instruction
 NOTE	Highlights an essential element of a procedure to ensure correctness.
 CAUTION!	Indicates a procedure or practice, which, if not strictly observed, could result in damage or destruction of equipment.
 WARNING!	Indicates error operation may cause death, serious injury and significant property damage.



CONTENTS

1	OVERVIEW	5
2	MODULES COMPARISON	6
3	PERFORMANCE AND CHARACTERISTICS	7
4	TECHNICAL PARAMETERS	8
5	OPERATOR INTERFACE	9
5.1	PUSHBUTTONS DESCRIPTION	9
5.2	LCD DISPLAY.....	10
5.2.1	Main Screen.....	10
5.2.2	Measured Data Display.....	10
6	OPERATION	12
6.1	START/STOP OPERATION OF EMERGENCY UNIT	12
6.2	LOCAL START/STOP OPERATION.....	13
7	PROTECTION	14
7.1	WARNING	14
7.2	SHUTDOWN ALARMS.....	18
8	PANEL CONFIGURATION	19
9	INPUT/OUTPUT PORTS CONFIGURATION	26
9.1	AUXILIARY INPUTS 1~18 FUNCTIONAL CONFIGURATION.....	26
9.1.1	Digital Input Port Configuration	26
9.1.2	Input Ports Functions	26
9.2	OUTPUT PORTS 1~14 FUNCTIONAL CONFIGURATION	28
9.3	SENSOR FUNCTIONAL CONFIGURATION	36
9.3.1	Sensor Configuration.....	36
9.3.2	Temperature Curves	37
9.3.3	Resistance Sensors Pressure Curves.....	37
9.3.4	Liquid Level Curves.....	38
10	BACK PANEL	39
11	TYPICAL WIRING DIAGRAM	42
12	RS485 COMMUNICATION AND CONNECTION	44
13	CONTROLLER AND ENGINES CONNECTION (EXPANSION CANBUS)	45
13.1	CUMMINS ISB/ISBE.....	45
13.2	CUMMINS QSL9.....	45
13.3	CUMMINS QSM11.....	46
13.4	DETROIT DIESEL DDEC III / IV.....	46
13.5	DEUTZ EMR2.....	46
13.6	JOHN DEERE	47



13.7	MTU MDEC	47
13.8	PERKINS	47
13.9	SCANIA	48
13.10	VOLVO EDC3	48
13.11	VOLVO EDC4	48
13.12	VOLVO-EMS2	49
13.13	BOSCH	49
13.14	EXPANSION MODULES	50
14	CONTROL PORT	51
15	INSTALLATION	51
16	TROUBLESHOOTING	52

SmartGen

1 OVERVIEW

HMC9000 diesel engine controller integrates digitization, intelligentization and network technology which are used for genset automation and monitor control system of single unit to achieve automatic start/stop, data measurement, alarm protection and “three remote” (remote control, remote measuring and remote communication). It fits with TFT-LCD display, optional Chinese/English languages interface, and it is reliable and easy to use.

The powerful 32-bit ARM processor contained within the module allows for precision parameters measuring, fixed value adjustment, time setting and set value adjusting and etc. Majority parameters can be configured from front panel or by communication interface via PC. Due to its compact structure, simple connections and high reliability, **HMC9000** enjoys wide application in all types of diesel engine automation systems. It can be widely used in marine emergency units, main propulsion units, main generator units and pumping units.

SAE J1939 interface of **HMC9000** diesel engine controller allows its communication with ECU engines. Multiple parameters such as engine speed, water temperature, oil temperature, oil pressure can be transmitted via this communication interface and displayed on LCD, so there is no need to install additional sensors and complicated wiring is avoided. This port also enables all kinds of module expansion; it combines fast data transmission, simple connections and high reliability.

HMC9000 diesel engine controller can be connected to a remote control module that will perform remote start, remote stop and other functions.

2 MODULES COMPARISON

HMC9000 series controllers are divided into 2 types: HMC9000S (Standard) and HMC9000E (Economy). The specific parameters are given as below:

Item	HMC9000S (Standard)	HMC9000E (Economy)	Remarks
LCD Size/Resolution	4.3" 480*272	4.3" 480*272	
Input Port	18	18	
Output Port	16	16	
Resistance Sensor	4	4	
Current Sensor	4	4	
Expand CANBUS Port	•		
Remote CANBUS Port	•	•	This port is used to expand not only HRM3300 remote monitor controller but also RPU560A security module. (If RPU560 is expanded, its baud rate should be set same as HRM3300.)
RS485 Port	•	•	
USB Port	•	•	
RPU560A Expand Module	•	•	
AIN16 Expand Module	•		
DIN16 Expand Module	•		
DOUT16A Expand Module	•		
LA16 Module Expand	•		
HRM3300 Expand Module	•	•	
AIN16-C Expand Module	•		
AIN16-PT Expand Module	•		
AIN16-M01 Expand Module	•		
GOV	•		

3 PERFORMANCE AND CHARACTERISTICS

- 32-bit ARM micro-processor, 4.3 inches LCD display with backlight, optional Chinese/English interface, push-button operation.
- Ability to control and communicate with dozens of ECU engines via J1939 interface which can also be connected to digital input module, digital output module, LED lamp indicator module, security module, meeting modules expanding needs of user.

▲ **Note:** This function is not available for HCM9000E.

- Remote monitoring and remote control via REMOTE (CANBUS) port; **HMC9000** panel lock in remote mode (except for 'stop' button), making work safe and convenient.
- RS485 and USB communication ports enable data transmission as well as remote control, remote measurement and remote communication to be performed with the help of PC monitoring software via MODBUS protocol;
- Control and protection: remote/local start and stop, alarm protection.
- Override mode, in which only overspeed shutdown and emergency shutdown will be able to stop the engine;
- Parameter setting: parameters can be modified and stored into internal FLASH memory and can not be lost even in case of power outage;
- Four 4-20mA inputs for pressure or liquid level sensors;
- Four resistance sensor inputs for pressure, PT100 temperature, liquid level or other sensors; also can perform the Electronic GOV function.
- Real-time calendar, real-time clock, engine total run-time accumulation;
- Display the total start times;
- Built-in watchdog to ensure smooth program execution.
- Built-in speed detection that accurately estimates starter disconnect speed, rated speed and overspeed.
- 99 event logs can be saved circularly and can be inquired on the spot.
- Two battery monitoring and transfer function; performed via external port according to the set switchover voltage value;
- Digital regulation of all parameters - instead of analog regulation using conventional potentiometer - and, therefore, higher reliability and stability;
- Multiple speed regulation ways: either via GOV voltage output port or via programmable output port;

▲ **Note:** This function is not available for HCM9000E.











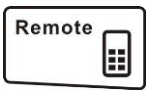

- Some Input/output ports have break wire detection function;
- Modular design, self extinguishing ABS plastic enclosure and embedded installation way; small size and compact structure with easy mounting

4 TECHNICAL PARAMETERS

Parameter	Details
Working Voltage	DC18.0V to DC35.0V, uninterrupted power supply.
Power Consumption	<3W (Standby mode: ≤2W)
Speed Sensor Voltage	1.0V to 24V (RMS)
Speed Sensor Frequency	Max 10,000 Hz
GOV Output Voltage	DC (-10~10)V
Start Relay Output	16 A Connect to common output port.
Fuel Relay Output	16 A Connect to common output port.
Auxiliary Relay Output 1	7 A Connect to common output port.
Auxiliary Relay Output 2	7 A Connect to common output port.
Auxiliary Relay Output 3	7 A Connect to common output port.
Auxiliary Relay Output 4	7 A Connect to common output port.
Auxiliary Relay Output 5	7 A Connect to common output port.
Auxiliary Relay Output 6	7 A 250VAC voltage free output
Auxiliary Transistor Output 7~14	B+ DC supply output. Output current: 0.5A.
Case Dimension	266 mm x 182 mm x 45mm
Panel Cutout	214mm x 160mm
Working Conditions	Temperature: (-25~70)°C; Humidity: (20~93)%RH
Storage Conditions	Temperature: (-25~70)°C
Protection Level	IP55 Gasket
Insulation Intensity	Apply AC2.2kV voltage between high voltage terminal and low voltage terminal; The leakage current is not more than 3mA within 1min.
Weight	0.90kg

5 OPERATOR INTERFACE

5.1 PUSHBUTTONS DESCRIPTION

	Stop	Stop running generator in local mode; During stopping process, press this button again to stop generator immediately.
	Start	Start genset in local mode.
	Remote Mode	Places controller into its remote mode. In remote mode, engine operation can be controlled via remote control module. In local mode, except for stop button, all the other panel buttons will be locked.
	Local Mode	Places controller into its local mode. In local mode, controller can be started using panel button while remote control will have no effect.
	Reset	If alarm occurs, pressing this button will reset it. All alarm only can be removed after reset.
	Lamp Test	Press this button will test panel LED indicators and display screen.
	Mute	Alarm sound off;
	Up/Increase	Screen scroll. Up cursor and increase value in setting menu.
	Down/Decrease	Screen scroll. Down cursor and increase value in setting menu.
	Left	Screen scroll. Left move cursor in setting menu.
	Right	Screen scroll. Right move cursor in setting menu.
	Set/Confirm	1. Pressing and holding for more than 3 seconds enters parameter configuration menu; 2. In settings menu confirms the set value
	Exit	1. Returns to the main screen. 2. In settings menu returns to the previous screen.

⚠WARNING: Factory default password is 00318. Operator can change the password to prevent others from free altering of the settings. Please clearly remember the password after changing. In case of password loss, please contact Smartgen service department enclosing all the information from the “ABOUT” page of the controller.

5.2 LCD DISPLAY

5.2.1 Main Screen

The main screen displays revolution meter (0~3000r/min), thermograph (0~150 °C; related sensor is user-configurable, for example: HMC9000 sensor 1), oil manometer (0~1000kpa; related sensor is user-configurable, for example: HMC9000 sensor 5) and two batteries voltage. The main screen displays as follows:

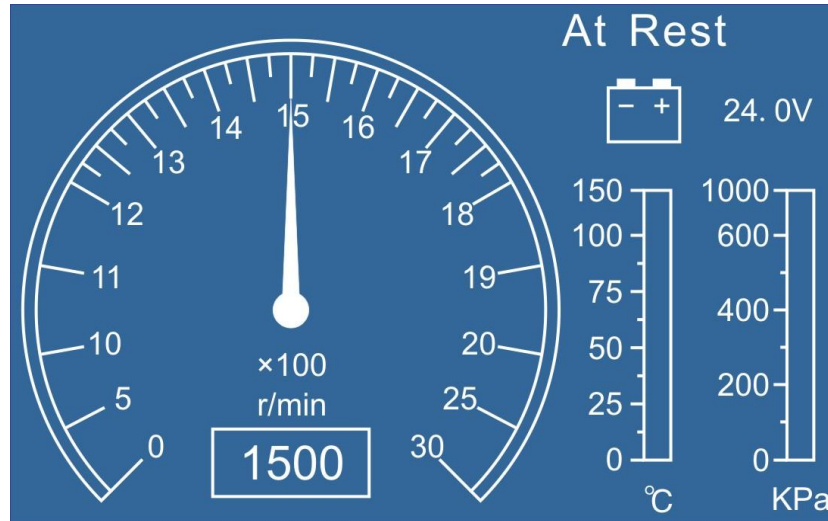

5.2.2 Measured Data Display

The main screen is divided into two separate viewing areas: right and left. Left area display status and cannot be scrolled; Right area can be scrolled using  button.

★**Status**, including as below:

Status of genset , power supply status.

★**Engine**, including as below:

Engine speed, sensors 1-4 (resistance type), sensors 5-8 (current type), main battery voltage, standby battery voltage, charger voltage, total running time, total start times and GOV output percentage.

(Note: sensor names are user-set)

★If J1939 is enabled, the following ECU data will also be displayed: coolant pressure, coolant level, oil temperature, fuel temperature, fuel pressure, inlet temperature, exhaust temperature, turbo pressure, fuel consumption, total fuel consumption and others. (Different engine with different parameters).

★ **Alarm**, including as below:

It displays all kinds of warning alarms and shutdown alarms which detected by controller.

▲**Note:** For ECU alarms and shutdown alarms, if the alarm information is displayed, check engine according to it, otherwise, please check the manual of generator according to SPN alarm code. HCM9000E has no J1939 port.

★**Event log**, including as below:

Records all shutdown events (shutdown alarm, trip and shutdown alarm) and the real time when alarm occurs.

★ **Others**, including as below:

Date and time, inputs/outputs status.

★About page includes:

Software version, hardware version

Engine page

Status	Engine
Generator Status	Engine Speed
Local Mode	1500RPM
Normal Running	Engine Temp.
Power Status	85°C 185°F
Main battery normal	Oil Pressure
Backup battery normal	465kPa 67.4psi 4.65bar
	Fuel Level
	100%
	Main battery Voltage
	27.6V
	Backup battery Voltage
	27.8V

SmartGen

6 OPERATION

6.1 START/STOP OPERATION OF EMERGENCY UNIT

Configure any programmable input port as remote start input. Remote mode is selected by pressing the



button; a LED besides the button will illuminate to confirm the operation.



Remote Start Sequence:

1. When "Remote Start" is active, "Start Delay" timer is initiated;
2. "Start Delay" countdown will be displayed on LCD;
3. When start delay is over, preheat relay energizes (if configured), "preheat delay XX s" information will be displayed on LCD;
4. After the above delay, the Fuel Relay is energized, and then one second later, the Start Relay is engaged. The engine is cranked for a pre-set time. If the engine fails to fire during this cranking attempt then the fuel relay and start relay are disengaged; "crank rest time" begins and wait for the next crank attempt.
5. Should this start sequence continue beyond the set number of attempts, the start sequence will be terminated, the first line of LCD display will be highlighted with black and Fail to Start fault will be displayed.
6. In case of successful crank attempt, the "Safety On" timer is activated, allowing Low Oil Pressure, High Temperature, Under speed and Charge Alternator Failure inputs to stabilise without triggering the fault. As soon as this delay is over, "start idle" delay is initiated (if configured).
7. During "start idle" delay, under speed alarm is inhibited. When this delay is over, "warming up" delay is initiated (if configured).
8. After the "warming up" delay, generator will enter into Normal Running status if engine speed and oil pressure are normal; if engine speed or oil pressure is abnormal, the controller will initiate shutdown alarm (shutdown alarm information will be displayed on LCD).

Remote Stop Sequence:

- 1) When the "Remote Start" signal is removed, the Stop Delay is initiated.
- 2) Once this "stop delay" has expired, the Generator Breaker will open and the "Cooling Delay" is then initiated. Once the "Cooling Delay" expires, the "Stop Idle" delay is initiated.
- 3) During "Stop Idle" Delay (if configured), idle relay is energized.
- 4) "ETS Solenoid Hold" begins, ETS relay is energized while fuel relay is de-energized.
- 5) "Fail to Stop Delay" begins, complete stop is detected automatically.
- 6) Generator is placed into its standby mode after its complete stop. Otherwise, fail to stop alarm is initiated and the corresponding alarm information is displayed on LCD (If generator is stop successfully after "fail to stop" alarm has initiated, generator is placed into its standby mode and the alarm will be removed after pressed Reset button.

6.2 LOCAL START/STOP OPERATION

Local mode is selected by pressing the  button; a LED besides the button will illuminate to confirm the operation; then press  button to start the gen-set; can detect crank disconnect condition and generator accelerates to high-speed running automatically. With high temperature, low oil pressure, over speed and abnormal voltage during generator running, controller can protect gen-set to stop quickly.

Local Start Sequence:

1. Press  button to start the gen-set; preheat relay energizes (if configured), "preheat delay XX s" information will be displayed on LCD;
2. After the above delay, the Fuel Relay is energized, and then one second later, the Start Relay is engaged. The engine is cranked for a pre-set time. If the engine fails to fire during this cranking attempt then the fuel relay and start relay are disengaged for the pre-set rest period; "crank rest time" begins and wait for the next crank attempt.
3. Should this start sequence continue beyond the set number of attempts, the start sequence will be terminated, the first line of LCD display will be highlighted with black and Fail to Start fault will be displayed.
4. In case of successful crank attempt, the "Safety On" timer is activated, allowing Low Oil Pressure, High Temperature, Under speed and Charge Alternator Failure inputs to stabilise without triggering the fault. As soon as this delay is over, "start idle" delay is initiated (if configured).
5. During "start idle" delay, under speed alarm is inhibited. When this delay is over, "warming up" delay is initiated (if configured).
6. When "warming up" delay is over, generator will enter into Normal Running status if engine speed and oil pressure are normal; if engine speed or oil pressure is abnormal, the controller will initiate shutdown alarm (alarm information will be displayed on LCD);

Local Stop Sequence:

- 1) Press  button to stop the gen-set and the "Cooling Delay" is then initiated.
- 2) The "Stop Idle" delay is initiated (if configured). During "Stop Idle" Delay, idle relay is energized.
- 3) "ETS Solenoid Hold" begins, ETS relay is energized while fuel relay is de-energized.
- 4) "Fail to Stop Delay" begins, complete stop is detected automatically.
- 5) Generator is placed into its standby mode after its complete stop. Otherwise, fail to stop alarm is initiated and the corresponding alarm information is displayed on LCD (If generator is stop successfully after "fail to stop" alarm has initiated, generator is placed into its standby mode and the alarm will be removed after pressed Reset button.

7 PROTECTION

7.1 WARNING

Warnings are not shutdown alarms and do not affect the operation of the gen-set. Warning alarms does not lead to shutdown and the detailed alarm information will be displayed on LCD.

Warning types are as follows:

No.	Type	Detection Range	Description
1	Over speed	Always active.	When the controller detects that the engine speed has exceeded the pre-set value, it will initiate a warning alarm and the corresponding alarm information will be displayed on LCD.
2	Under speed	From "Waiting for load" delay to "Cooling" delay	When the controller detects that the engine speed has fallen below the pre-set value, it will initiate a warning alarm and the corresponding alarm information will be displayed on LCD.
3	Loss of Speed Signal	From "Start Idle" delay to "Stop Idle" delay	When the controller detects that the engine speed is 0, it will initiate a warning alarm and the corresponding alarm information will be displayed on LCD.
4	Failed to stop	After "Fail to Stop" Delay	After "fail to stop" delay, if gen-set does not stop completely, it will initiate a warning alarm and the corresponding alarm information will be displayed on LCD.
5	Charge Alt Fail	When generator is normal running	When the controller detects that charger voltage has fallen below the pre-set value, it will initiate a warning alarm and the corresponding alarm information will be displayed on LCD.
6	Auxiliary Input 1-18	User defined	When the controller detects that the auxiliary input 1-18 warning signals, it will initiate a warning alarm and the corresponding alarm information will be displayed on LCD.
7	ECU warn	Always active.	If an error message is received from ECU, it will initiate a warning alarm and the corresponding alarm information will be displayed on LCD.
8	Sensor 1~8 High	From "Waiting for load" delay to "Cooling" delay	When the controller detects that the sensor 1-8 warning signals, it will initiate a warning alarm and the corresponding alarm information will be displayed on LCD.
9	Sensor 1~8 Low	From "Waiting for load" delay to "Cooling" delay	When the controller detects that the sensor 1-8 warning signals, it will initiate a warning alarm and the corresponding alarm information will be displayed on LCD.
10	Sensor 1~8 Open	Always active.	When the controller detects that the sensor 1-8 warning signals, it will initiate a warning alarm and the corresponding alarm information will be displayed on LCD.
11	Bat 1 under volt	Always active.	When the controller detects that the B1 battery voltage has fallen below the pre-set value for more than 20s, it will initiate a warning alarm and



No.	Type	Detection Range	Description
			the corresponding alarm information will be displayed on LCD.
12	Bat 1 over volt	Always active.	When the controller detects that the B1 battery voltage has exceeded the pre-set value, it will initiate a warning alarm and the corresponding alarm information will be displayed on LCD.
13	Bat 2 under volt	Always active.	When the controller detects that the B2 battery voltage has fallen below the pre-set value for more than 20s, it will initiate a warning alarm and the corresponding alarm information will be displayed on LCD.
14	Bat 2 over volt	Always active.	When the controller detects that the B2 battery voltage has exceeded the pre-set value, it will initiate a warning alarm and the corresponding alarm information will be displayed on LCD.
15	Speed BW Warn	Always active.	When the controller detects speed disconnection, it will initiate a warning alarm and the corresponding alarm information will be displayed on LCD.
16	Fuel BW Warn	Always active.	When the controller detects fuel disconnection, it will initiate a warning alarm and the corresponding alarm information will be displayed on LCD.
17	Input 1 BW Warn	Always active. (When disconnection detection is enabled)	When the controller detects input port 1 disconnection, it will initiate a warning alarm and the corresponding alarm information will be displayed on LCD.
18	Input 2 BW Warn	Always active. (When disconnection detection is enabled)	When the controller detects output port 2 disconnection, it will initiate a warning alarm and the corresponding alarm information will be displayed on LCD.
19	Input 3 BW Warn	Always active. (When disconnection detection is enabled)	When the controller detects input port 3 disconnection, it will initiate a warning alarm and the corresponding alarm information will be displayed on LCD.
20	Input 4 BW Warn	Always active. (When disconnection detection is enabled)	When the controller detects input port 4 disconnection, it will initiate a warning alarm and the corresponding alarm information will be displayed on LCD.
21	Input 5 BW Warn	Always active. (When disconnection detection is enabled)	When the controller detects input port 5 disconnection, it will initiate a warning alarm and the corresponding alarm information will be displayed on LCD.
22	Input 6 BW Warn	Always active. (When disconnection detection is enabled)	When the controller detects input port 6 disconnection, it will initiate a warning alarm and the corresponding alarm information will be displayed on LCD.
23	Output 1 BW Warn	Always active. (When disconnection detection is	When the controller detects output port 1 disconnection, it will initiate a warning alarm and



No.	Type	Detection Range	Description
		enabled)	the corresponding alarm information will be displayed on LCD.
24	Output 2 BW Warn	Always active. (When disconnection detection is enabled)	When the controller detects output port 2 disconnection, it will initiate a warning alarm and the corresponding alarm information will be displayed on LCD.
25	Output 3 BW Warn	Always active. (When disconnection detection is enabled)	When the controller detects output port 3 disconnection, it will initiate a warning alarm and the corresponding alarm information will be displayed on LCD.
26	RPU Com Fail	Always active (When RPU560A is enabled).	When the controller detects RPU560A module communication failure, it will initiate a warning alarm and the corresponding alarm information will be displayed on LCD.
27	AIN1 Com Fail	Always active (When AIN1 is enabled).	When the controller detects AIN1 module communication failure, it will initiate a warning alarm and the corresponding alarm information will be displayed on LCD.
28	AIN2 Com Fail	Always active (When AIN2 is enabled).	When the controller detects AIN2 module communication failure, it will initiate a warning alarm and the corresponding alarm information will be displayed on LCD.
29	DIN1 Com Fail	Always active (When DIN1 is enabled).	When the controller detects DIN1 module communication failure, it will initiate a warning alarm and the corresponding alarm information will be displayed on LCD.
30	DIN2 Com Fail	Always active (When DIN2 is enabled).	When the controller detects DIN2 module communication failure, it will initiate a warning alarm and the corresponding alarm information will be displayed on LCD.
31	DOUT1 Com Fail	Always active (When DOUT1 is enabled).	When the controller detects DOUT1 module communication failure, it will initiate a warning alarm and the corresponding alarm information will be displayed on LCD.
32	DOUT2 Com Fail	Always active (When DOUT2 is enabled).	When the controller detects DOUT2 module communication failure, it will initiate a warning alarm and the corresponding alarm information will be displayed on LCD.
33	LED1 Com Fail	Always active (When LA1 is enabled).	When the controller detects LA1 module communication failure, it will initiate a warning alarm and the corresponding alarm information will be displayed on LCD.
34	LED2 Com Fail	Always active (When LA2 is enabled).	When the controller detects LA2 module communication failure, it will initiate a warning alarm and the corresponding alarm information will be displayed on LCD.
35	AIN-C1 Com Fail	Always active (When AIN-C1 is enabled)	When the controller detects AIN-C1 module communication failure, it will initiate a warning alarm and the corresponding alarm information



No.	Type	Detection Range	Description
			will be displayed on LCD.
36	AIN-C2 Com Fail	Always active (When AIN-C2 is enabled)	When the controller detects AIN-C2 module communication failure, it will initiate a warning alarm and the corresponding alarm information will be displayed on LCD.
37	AIN-PT1 Com Fail	Always active (When AIN-PT1 is enabled)	When the controller detects AIN-PT1 module communication failure, it will initiate a warning alarm and the corresponding alarm information will be displayed on LCD.
38	AIN-PT2 Com Fail	Always active (When AIN-PT2 is enabled)	When the controller detects AIN-PT2 module communication failure, it will initiate a warning alarm and the corresponding alarm information will be displayed on LCD.
39	AIN-M01 1 Com Fail	Always active (When AIN-M01 1 is enabled)	When the controller detects AIN-M01 1 module communication failure, it will initiate a warning alarm and the corresponding alarm information will be displayed on LCD.
40	AIN-M01 2 Com Fail	Always active (When AIN-M01 2 is enabled)	When the controller detects AIN-M01 2 module communication failure, it will initiate a warning alarm and the corresponding alarm information will be displayed on LCD.

△Note: The warning types of Auxiliary input are active only when they are configured by users. External input port alarms are only active when it is configured as external expansion panel input.

△Notes:

AIN1: 16-channel analogue input expansion module 1

AIN2: 16-channel analogue input expansion module 2

DIN1: 16-channel digital input expansion module 1

DIN2: 16-channel digital input expansion module 2

DOUT1: 16-channel digital output expansion module 1

DOUT2: 16-channel digital output expansion module 2

LA1: 16-channel LED lamp expansion module 1

LA2: 16-channel LED lamp expansion module 2

RPU560A: security expansion module

AIN-C 1: 16-channel 4-20mA analogue input expansion module 1

AIN-C 2: 16-channel 4-20mA analogue input expansion module 2

AIN-PT 1: 16-channel PT100 analogue input expansion module 1

AIN-PT 2: 16-channel PT100 analogue input expansion module 2

AIN-M01 1: analogue input/output expansion module 1

AIN-M01 2: analogue input/output expansion module 2

7.2 SHUTDOWN ALARMS

When controller detects shutdown alarm, it will send signal to open breaker and shuts down generator and the detailed alarm information will be displayed on LCD.





Shutdown alarms as following:





No.	Type	Detection range	Description
1	Emergency Stop	Always active	When the controller detects an emergency stop alarm signal, it will initiate a shutdown alarm and the corresponding alarm information will be displayed on LCD.
2	Over speed	Always active	When the controller detects that the generator speed has exceeded the pre-set value, it will initiate a shutdown alarm and the corresponding alarm information will be displayed on LCD.
3	Under speed	From "Waiting for load" delay to "Cooling" delay	When the controller detects that the generator speed has fallen below the pre-set value, it will initiate a shutdown alarm and the corresponding alarm information will be displayed on LCD.
4	Loss of Speed Signal	From "Start Idle" delay to "Stop Idle" delay	When the controller detects that the genset speed is 0, it will initiate a shutdown alarm and the corresponding alarm information will be displayed on LCD.
5	Failed To Start	If the engine does not fire after the pre-set number of attempts.	If the engine does not fire after the pre-set number of attempts, it will initiate a shutdown alarm and the corresponding alarm information will be displayed on LCD.
6	Auxiliary Input 1-18	User defined	When the controller detects that the auxiliary input 1-18 shutdown alarm, it will initiate a shutdown alarm and the corresponding alarm information will be displayed on LCD.
7	ECU Shutdown	Always active	When the controller detects ECU shutdown alarm, it will initiate a shutdown alarm and the corresponding alarm information will be displayed on LCD.
8	ECU Com Fail	Do not detect in stop or standby mode.	If the module detects that there is no CAN data, it will initiate a shutdown alarm and the corresponding alarm information will be displayed on LCD.
9	Sensor 1~8 High	From "Waiting for load" delay to "Cooling" delay	When the controller detects that the sensor 1-8 shutdown alarm, it will initiate a shutdown alarm and the corresponding alarm information will be displayed on LCD.
10	Sensor 1~8 Low	From "Waiting for load" delay to "Cooling" delay	When the controller detects that the sensor 1-8 shutdown alarm, it will initiate a shutdown alarm and the corresponding alarm information will be displayed on LCD.





△Note: Auxiliary input port shutdown alarm types are only active when they are configured by users. In override mode only emergency stop and over speed stop will be able to stop the engine.

8 PANEL CONFIGURATION

Pressing and holding  button for more than 3 seconds will enter the configuration menu, which allows users to set all kinds of parameters, as follows:

Return	>Start Delay	Form1: Use   to scroll settings,  to enter settings (form 2),  to exit settings menu.
Module Set	>Stop Delay	
Timers Set >	>Preheat Delay	
Engine Set	>Cranking Time	
Sensor Set	>Crank Rest Time	
Digital Inputs	>Safety On Time	
Relay Outputs	>Start Idle Time	
	>Warming Up Time	
	>Cooling Time	
	>Stop Idle Time	
	>ETS Hold Time	
	>Fail to Stop	

Return	> Start Delay	Form 2: Use   to scroll settings,  to enter settings (form 4),  to return to the previous screen (form 1).
Module Set	>Stop Delay	
Timer Set >	>Preheat Delay	
Engine Set	>Cranking Time	
Sensor Set	>Crank Rest Time	
Digital Inputs	>Safety On time	
Relay Outputs	>Start Idle time	
	>Warming Up time	
	>Cooling Time	
	>Stop Idle Time	
	>ETS Hold Time	
	>Fail to Stop	

Return	>Start Delay	Form 3: Use   to scroll settings,  to enter settings (form 4),  to return to the previous screen (form 1).
Module Set	>Stop Delay	
	>Preheat Delay	
Timer Set	> Cranking Time	
Engine Set	>Crank Rest Time	
Sensor Set	>Safety On Time	
Digit Inputs	>Start Idle Time	
Relay Outputs	>Warming Up time	
	>Cooling Time	
	>Stop Idle Time	
	>ETS Hold Time	
	>Fail to Stop	

>Start Delay >Stop Delay >Preheat Delay	00008	Form 4: Press to enter settings (form 5), to return to the previous screen (form 6).
>Cranking Time		
>Crank Rest Time >Safety On Time >Start Idle Time >Warming Up Time >Cooling Time >Stop Idle Time >ETS Hold Time >Fail to Stop		

>Start Delay >Stop Delay >Preheat Delay	00008	Form 5: Press to change cursor position, are used for changing cursor value, Confirm setting (form 4), exit setting (form 4).
>Cranking Time		
>Crank Rest Time >Safety On Time >Start Idle Time >Warming Up Time >Cooling Time >Stop Idle Time >ETS Hold Time >Fail to Stop		

>Start Delay >Stop Delay >Preheat Delay	00008	Form 6: are used for changing the setting contents. to enter settings (form 4), to return to the previous screen (return to form 1).
>Cranking Time		
>Crank Rest Time >Safety On Time >Start Idle Time >Warming Up Time >Cooling Time >Stop Idle Time >ETS Hold Time >Fail to Stop		

Note: Pressing can exit setting directly during setting.

Parameter Configuration List

Parameter	Range	Default	Remarks
1. Start delay	(0-3600)s	1	Timer setting
2. Stop delay	(0-3600)s	1	Timer setting
3. Preheat delay	(0-3600)s	0	Timer setting
4. Cranking Time	(3-60s)	8	Timer settings
5. Crank rest Time	(3-60s)	10	Timer settings
6. Safety on Time	(0-3600)s	10	Timer settings
7. Start idle time	(0-3600)s	0	Timer settings
8. Warming up time	(0-3600)s	10	Timer settings
9. Cooling time	(0-3600)s	10	Timer settings
10. Stop idle time	(0-3600)s	0	Timer settings
11. ETS hold time	(0-3600)s	20	Timer settings
12. Fail to Stop	(0-3600)s	0	Timer settings
13. J1939 Enable	(0-1)	0 Disable	Engine settings HMC9000E without
14. Engine type	(0-39)	0 Normal Genset	Engine settings HMC9000E without
15. SPN version	(1-3)	Version 1	Engine settings HMC9000E without
16. Flywheel teeth	(1-300)	118	Engine settings
17. Rated speed	(1-5999)r/min	1500	Engine settings
18. Speed On load	(0-200)%	90%	Engine settings
19. Oil Pressure On Load	(1-1000)kpa (Related to sensor 5)	200	Engine settings
20. Start Attempts	(1-30)	3	Engine settings
21. Disc. Condition	(0-2) 0: Engine Speed 1: Oil Pressure 2: Engine Speed+ Oil Pressure	0: Engine Speed	Engine settings
22. Disconnect Speed	(0-200)%	25%	Engine settings
23. Disconnect OP	(10-1000)	80	Engine settings
24. Under Speed Shut	(0-200)%	85%	Engine settings
25. Under Speed Delay	(0-3600)s	1	Engine settings
26. Under Speed Warn	(0-200)%	90%	Engine settings
27. Under Speed Return	(0-200)%	92%	Engine settings
28. Over Speed Shut	(0-200)%	115%	Engine settings
29. Over Speed Delay	(0-3600)s	1	Engine settings
30. Over Speed Warn	(0-200)%	110%	Engine settings
31. Over Speed Return	(0-200)%	108%	Engine settings
32. Speed Lose Delay	(0-3600)s	1	Engine settings
33. Speed Lose Act	(0-2) 0: No Action 1: Shutdown 2: Warn	1: Shutdown	Engine settings
34. Charge Alt Fail	(0-60.0)V	16.0	Engine settings

Parameter	Range	Default	Remarks
35. Bat Rated Volt	(0-60.0)V	24.0	Engine settings
36. Bat1 Over Volt	(0-200)%	125%	Engine settings
37. Bat2 Over Volt	(0-200)%	125%	Engine settings
38. Bat1 Under Volt	(0-200)%	75%	Engine settings
39. Bat2 Under Volt	(0-200)%	75%	Engine settings
40. Main Switch Spare Volt	(0-200)%	75%	Engine settings
41. Spare Switch Main Volt	(0-200)%	90%	Engine settings
42. Adjust Up Limit	(0-200)%	120%	Engine settings
43. Adjust Down Limit	(0-200)%	80%	Engine settings
44. GOV Center Volt	(0-5.0)V	0	Engine settings HMC9000E without
45. GOV Out Area	(0-10.0)V	0	Engine settings HMC9000E without
46. GOV Out RP	(0-1) 0: Disabled 1: Enabled	0	Engine settings HMC9000E without
47. Heating Up Limit	(0-100)°C	42	Engine settings
48. Heating Down Limit	(0-100) °C	37	Engine settings
49. Fuel Pump Out	(0-100)%	20	Engine settings
50. Fuel Pump Cut	(0-100)%	30	Engine settings
51. Cyc Lubri Enable	(0-1) 0:Disabled 1:Enable	0	Engine settings
52. Cyc Gap Time	(0-7200)min	300	Engine settings
53. Lubri Time	(0-7200)s	300	Engine settings
54. Device ID	(1-254)	1	Module settings
55. Language select	(0-1) 0: Chinese 1: English	0: Chinese	Module settings
56. Password set	(0-9999)	01234	Module settings
57. Power On Mode	(0-1) 0: Local mode 1: Remote mode	0	Module settings
58. RS485 Baud set	(0-4) 0: 2400 bps 1:4800bps 2:9600bps 3:19200bps 4: 38400bps	2: 9600bps	Module settings RS485 Baud Rate
59. RPU560A Enable	(0-1)	0: Disabled	Module settings
60. DOUT1 Enable	(0-1)	0: Disabled	Module settings HMC9000E without
61. DOUT2 Enable	(0-1)	0: Disabled	Module settings HMC9000E without
62. DIN1 Enable	(0-1)	0: Disabled	Module settings HMC9000E without
63. DIN2 Enable	(0-1)	0: Disabled	Module settings HMC9000E without



Parameter	Range	Default	Remarks
64. AIN1 Enable	(0-1)	0: Disabled	Module settings HMC9000E without
65. AIN 2 Enable	(0-1)	0: Disabled	Module settings HMC9000E without
66. LA 1 Enable	(0-1)	0: Disabled	Module settings HMC9000E without
67. LA2 Enable	(0-1)	0: Disabled	Module settings HMC9000E without
68. Expand Module Baud Rate	(0-1) 0: 250kbps 1: 125kbps	0: 250kbps	Module settings
69. AIN-C 1 Enable	(0-1)	0: Enabled	Module settings HMC9000E without
70. AIN-C 2 Enable	(0-1)	0: Enabled	Module settings HMC9000E without
71. AIN-PT 1 Enable	(0-1)	0: Enabled	Module settings HMC9000E without
72. AIN-PT 2 Enable	(0-1)	0: Enabled	Module settings HMC9000E without
73. AIN-M01 1 Enable	(0-1)	0: Enabled	Module settings HMC9000E without
74. AIN-M01 2 Enable	(0-1)	0: Enabled	Module settings HMC9000E without
75. Time Settings		Current Time	Module settings
76. Sensor 1 set (Resistance input, default: coolant temperature)	See 8.3. Sensor function settings Note: Resistance type input range is not applicable.		Sensor settings
77. Sensor 2 set (Resistance input, default: Oil temperature)	See 8.3. Sensor function settings Note: Resistance type input range is not applicable.		Sensor settings
78. Sensor 3 set (Custom Sensor1)	See 8.3. Sensor function settings Note: Resistance type input range is not applicable.		Sensor settings
79. Sensor 4 set (Resistance input, default: fuel level)	See 8.3. Sensor function settings Note: Resistance type input range is not applicable.		Sensor settings
80. Sensor 5 set (4~20mA input, default: oil pressure)	See 8.3. Sensor function settings		Sensor settings
81. Sensor 6 set (Custom Sensor2)	See 8.3. Sensor function settings		Sensor settings
82. Sensor 7 set (Custom Sensor3)	See 8.3. Sensor function settings		Sensor settings
83. Sensor 8 set (Custom Sensor4)	See 8.3. Sensor function settings		Sensor settings
84. Input 1 Set	(0-50)	15: Over Ride Mode Input	Input port setting
85. Active type	(0-1)	0: Close to activate	Input port setting
86. Input 2 Set	(0-50)	16: Emergency Stop	Input port setting
87. Active type	(0-1)	0: Close to activate	Input port setting



Parameter	Range	Default	Remarks
88. Input 3 Set	(0-50)	1: Custom (Fuel Leak)	Input port setting
89. Active type	(0-1)	0: Close to activate	Input port setting
90. Input 4 Set	(0-50)	1: Custom (Air Pressure Low)	Input port setting
91. Active type	(0-1)	0: Close to activate	Input port setting
92. Input 5 Set	(0-50)	1: Custom (Crankcase Pressure Low)	Input port setting
93. Active type	(0-1)	0: Close to activate	Input port setting
94. Input 6 Set	(0-50)	4: Raise Speed	Input port setting
95. Active type	(0-1)	0: Close to activate	Input port setting
96. Input 7 Set	(0-50)	5: Drop Speed	Input port setting
97. Active type	(0-1)	0: Close to activate	Input port setting
98. Input 8 Set	(0-50)	11: Remote Start	Input port setting
99. Active type	(0-1)	0: Close to activate	Input port setting
100. Input 9 Set	(0-50)	12: Remote Stop	Input port setting
101. Active type	(0-1)	0: Close to activate	Input port setting
102. Input 10 Set	(0-50)	31: Turning Chain	Input port setting
103. Active type	(0-1)	0: Close to activate	Input port setting
104. Input 11 Set	(0-50)	0: Not Used	Input port setting
105. Active type	(0-1)	0: Close to activate	Input port setting
106. Input 12 Set	(0-50)	0: Not Used	Input port setting
107. Active type	(0-1)	0: Close to activate	Input port setting
108. Input 13 Set	(0-50)	0: Not used	Input port setting
109. Active type	(0-1)	0: Close to activate	Input port setting
110. Input 14 Set	(0-50)	0: Not used	Input port setting
111. Active type	(0-1)	0: Close to activate	Input port setting
112. Input 15 Set	(0-50)	0: Not used	Input port setting
113. Active type	(0-1)	0: Close to activate	Input port setting
114. Input 16 Set	(0-50)	0: Not used	Input port setting
115. Active type	(0-1)	0: Close to activate	Input port setting
116. Input 17 Set	(0-50)	0: Not used	Input port setting
117. Active type	(0-1)	0: Close to activate	Input port setting
118. Input 18 Set	(0-50)	0: Not used	Input port setting
119. Active type	(0-1)	0: Close to activate	Input port setting
120. Output 1 Set	(0-190)	8: ETS Hold	Output port setting
121. Output type	(0-1)	0: Normally open	Output port setting
122. Output 2 set	(0-190)	71: Over Speed Shutdown	Output port setting
123. Output type	(0-1)	0: Normally open	Output port setting
124. Output 3 set	(0-190)	75: Fail To Start	Output port setting
125. Output type	(0-1)	0: Normally open	Output port setting
126. Output 4 set	(0-190)	3: Audible Alarm	Output port setting
127. Output type	(0-1)	0: Normally open	Output port setting
128. Output 5 set	(0-190)	18: Ready Go	Output port setting
129. Output type	(0-1)	0: Normally open	Output port setting
130. Output 6 set	(0-190)	49: Crank Success	Output port setting



Parameter	Range	Default	Remarks
131. Output type	(0-1)	0: Normally open	Output port setting
132. Output 7 set	(0-190)	27: Common Alarm	Output port setting
133. Output type	(0-1)	0: Normally open	Output port setting
134. Output 8 set	(0-190)	2: Air flap	Output port setting
135. Output type	(0-1)	0: Normally open	Output port setting
136. Output 9 set	(0-190)	15: Pre-lubricate	Output port setting
137. Output type	(0-1)	0: Normally open	Output port setting
138. Output 10 set	(0-190)	50: Normal Running	Output port setting
139. Output type	(0-1)	0: Normally open	Output port setting
140. Output 11 set	(0-190)	0: Not Used	Output port setting
141. Output type	(0-1)	0: Normally open	Output port setting
142. Output 12 set	(0-190)	0: Not Used	Output port setting
143. Output type	(0-1)	0: Normally open	Output port setting
144. Output 13 set	(0-190)	0: Not Used	Output port setting
145. Output type	(0-1)	0: Normally open	Output port setting
146. Output 14 set	(0-190)	0: Not Used	Output port setting
147. Output type	(0-1)	0: Normally open	Output port setting

Other parameters (see table below) can only be configured via PC.

Parameter	Contents
Resistance sensor 1 settings	User-defined sensor curve settings
Resistance sensor 2 settings	User-defined sensor curve settings
Resistance sensor 3 settings	User-defined sensor curve settings
Resistance sensor 4 settings	User-defined sensor curve settings
Sensor 1~8 name settings	User-defined sensor name
Output 1 custom settings	Name / Button/ Active period /Output delay / Output time
Output 2 custom settings	Name / Button/ Active period /Output delay / Output time
Output 3 custom settings	Name / Button/ Active period /Output delay / Output time
Output 4 custom settings	Name / Button/ Active period /Output delay / Output time
Output 5 custom settings	Name / Button/ Active period /Output delay / Output time
Output 6 custom settings	Name / Button/ Active period /Output delay / Output time
Output 7 custom settings	Name / Button/ Active period /Output delay / Output time
Output 8 custom settings	Name / Button/ Active period /Output delay / Output time
Output 9 custom settings	Name / Button/ Active period /Output delay / Output time
Output 10 custom settings	Name / Button/ Active period /Output delay / Output time
Output 11 custom settings	Name / Button/ Active period /Output delay / Output time
Output 12 custom settings	Name / Button/ Active period /Output delay / Output time
Output 13 custom settings	Name / Button/ Active period /Output delay / Output time
Output 14 custom settings	Name / Button/ Active period /Output delay / Output time

9 INPUT/OUTPUT PORTS CONFIGURATION

9.1 AUXILIARY INPUTS 1~18 FUNCTIONAL CONFIGURATION



9.1.1 Digital Input Port Configuration

No.	Settings	Contents	Description
1	Feature Set	(0-50)	See 8.1.2 INPUT PORT FUNCTIONS
2	Active type	(0-1)	0: Close to activate 1: Open to activate
3	Arming	(0-3)	0: From Safety on 1: From Crank 2: Always 3: Never
4	Active action	(0-4)	0: Warn 1: Shutdown 2: Indication
5	Input Delay	(0-20.0)s	
6	Open Check Enable	(0-1)	0:Disabled 1:Enable Only input ports 1~6 and speed input have this function.
7	Display string	User-defined input port names	20 English symbols or 10 Chinese characters

9.1.2 Input Ports Functions

No.	Function	Description
0	Not used	
1	User-defined	Users configured input port settings
2	Alarm Mute	Can prohibit "Audible Alarm" output when input is active.
3	Reset alarm	Can reset all alarms when input is active.
4	Raise Speed	The generator will increase speed by GOV when the input is active.
5	Drop Speed	The generator will decrease speed by GOV when the input is active.
6	Reserved	
7	Reserved	
8	Lamp test	All LED indicators are illuminating when input is active.
9	Local mode in	Local mode is activated when input is active.
10	Remote mode in	Remote mode is activated when input is active.
11	Remote start	Automatically starts the generator in remote mode when the input is active. Only the active shutdown input will be able to stop the generator. (Inch or hold the button for more than 1s)
12	Remote stop	Stops the generator in remote mode when the input is active.
13	Remote start/stop	Automatically starts the generator in remote mode; the generator will shut down when this input is deactivated.
14	Pre-lubricate	If output is set as pre-lubrication output, the relay disconnects after the set pre-lubrication delay.



15	Override mode in	Override mode is activated when the input is active; in override mode only overspeed shutdown and emergency shutdown will stop the engine.
16	Emergency stop	The controller shuts down the engine immediately and records occurrence time.
17	Panel lock	All buttons in panel is inactive except  and there is  in the left of first row in LCD when input is active.
18	Reserved	
19	Power Change	Transfers from main battery to standby battery.
20	Raise Speed Aid	Raise speed relay will disconnect when the input is active.
21	Reserved	
22	Drop Speed Aid	Drop speed relay will disconnect when the input is active.
23	Water Heating feedback	The feedback signal of water heating output; The screen displays <i>Water Heating feedback</i> when the input is active.
24	Pre-lube feedback	The feedback signal of Pre-lube output; The screen displays <i>Pre-lube feedback</i> when the input is active.
25	Charging feedback	The feedback signal of Charging output; The screen displays <i>Charging feedback</i> when the input is active.
26	Reserved	
27	Reserved	
28	Quick start	Cranking will start directly (without preheating) when the input is active.
29	Reserved	
30	60Hz Select	Frequency selection of ECU engine
31	Turning Chain	Start inhibition when the input is active.
32	Clean Cylinder	Start relay outputs when clean cylinder input is active.
33	Reserved	Reserved
34	Self-check	Alarms can test with no rotated speed when self-check input is active.
35-50	Reserved	

▲Note: The name of the input ports 1~18 only can be configured via PC software.

9.2 OUTPUT PORTS 1~14 FUNCTIONAL CONFIGURATION

Output Port Configuration

No.	Items	Contents	Remarks
1	Feature set	(0-255)	
2	Active type	0: Normally Open 1: Normally Close	
3	Button output	0 Lamp Test Button 1 Start Button 2 Stop Button 3 Reset Button 4 Mute Button 5 Local Mode Button 6 Remote Mode Button	
4	Active period	Bit0: Not used Bit1: At rest Bit2: Preheating Bit3: Fuel on Bit4: Cranking Bit5: Crank rest Bit6: Safety on Bit7: Start idle Bit8: Warming up Bit9: Wait for load Bit10: Normal running Bit11: Cooling down Bit12: Stop idle delay Bit13: ETS hold Bit14: Wait For Stop Bit15: Fail to stop	
5	Output delay	(0-100.0)s	
6	Output time	(0-3600)s	
7	Enable BW detection	0: Do not detect 1: Detect	Only outputs 1-3 and oil output port have this function.

Output Port Functions:

NO.	Items	Description
00	Not used	
01	User Configured	See 8.2
02	Air flap	Action when over speed shutdown and emergence stop. It also can close the air inflow to stop the engine as soon as possible.
03	Audible alarm	Action when warning, shutdown. Can be connected annunciator externally. When "alarm mute" configurable input port is active, it can remove the alarm.
04	ECU power	Used for ECU engine.
05	ECU Stop	Used for ECU engine.
06	Crank Relay	Action when genset is starting and disconnect when crank success.
07	Fuel Relay	Action when genset is starting and disconnect when stop is



		completed.
08	ETS Hold	Action period: ETS hold delay.
09	Reserved	
10	Fuel Pump Control	It is controlled by fuel pump of level sensor's limited threshold.
11	Reserved	
12	Louver Control	Action when generator is starting and disconnect when generator is stopped completely.
13	Loss of Speed	After safety on delay, the controller activates when the engine speed is 0.
14	Heater Control	The controller disconnects when water temperature is lower than minimum setting threshold value or higher than maximum setting threshold value.
15	Pre-lubricate	The controller output when the engine is in standby mode (user-defined output delay) if pre-lubrication input is active.
16	Remote PC Output	The controller output when remote control is active however disconnect when inactive.
17	Over Ride Output	The controller output when it is in override mode.
18	Ready Go	The controller output when it is in standby mode and no alarms.
19	Reserved	
20	Idle Control	Action from "crank delay" to "start idle delay" and from "stop idle delay" to "wait for stop delay".
21	Pre-Supply Fuel	Action from "crank delay" to "safety on delay".
22	Raise Speed	Mechanical Governor: The controller outputs when Raise Speed Output is active; however, disconnect when inactive. ECU Governor: Users can govern speed via this port. User-defined rate.
23	Drop Speed	Mechanical Governor: The controller outputs when Speed Droop Output is active; however, disconnect when inactive. ECU Governor: Users can govern speed via this port. User-defined rate.
24	Crank Again	The relay outputs when controller fails to start and starts again if the configuration is active (expansion relay is needed).
25	Power Change	Action when battery 1 voltage has fallen below the transfer value. Deactivate when battery 1 voltage has exceed the transfer value.
26	High Speed	The controller act from warming up delay to cooling down delay. (contrary to idle speed output)
27	Common Alarm	Action when generator common warning, common shutdown alarm.
28	Common Shutdown	Action when common shutdown alarm.
29	Common Warn	Action when common warning alarm.
30	Aux. Input 1 Active	Action when input port 1 is active.
31	Aux. Input 2 Active	Action when input port 2 is active.
32	Aux. Input 3 Active	Action when input port 3 is active.
33	Aux. Input 4 Active	Action when input port 4 is active.



34	Aux. Input 5 Active	Action when input port 5 is active.
35	Aux. Input 6 Active	Action when input port 6 is active.
36	Aux. Input 7 Active	Action when input port 7 is active.
37	Aux. Input 8 Active	Action when input port 8 is active.
38	Aux. Input 9 Active	Action when input port 9 is active.
39	Aux. Input 10 Active	Action when input port 10 is active.
40	Aux. Input 11 Active	Action when input port 11 is active.
41	Aux. Input 12 Active	Action when input port 12 is active.
42	Aux. Input 13 Active	Action when input port 13 is active.
43	Aux. Input 14 Active	Action when input port 14 is active.
44	Aux. Input 15 Active	Action when input port 15 is active.
45	Aux. Input 16 Active	Action when input port 16 is active.
46	Aux. Input 17 Active	Action when input port 17 is active.
47	Aux. Input 18 Active	Action when input port 18 is active.
48	Reserved	
49	Crank Success	The gen-set start when the engine speed reaches requirements.
50	Normal Running	The gen-set is normal running when the rated speed is reached.
51	Remote Mode	The controller output in remote control mode.
52	Local Mode	The controller output in local mode.
53	Waiting For Load	The controller output in Waiting For Load delay.
54	AIN16-C Com Fail	Action when the controller detects communication failure with AIN16-C. (3s overtime)
55	AIN16-PT Com Fail	Action when the controller detects communication failure with AIN16-PT. (3s overtime)
56	Pulse Stop	Action during stop delay while deactivate after the delay.
57	AIN16 Com Fail	Action when the controller detects communication failure with AIN16. (3s overtime)
58	DIN16 Com Fail	Action when the controller detects communication failure with DIN16. (3s overtime)
59	RPU560A Com Fail	Action when the controller detects communication failure with RPU560A safeguard module. (1s overtime)
60	DOUT16A Com Fail	Action when the controller detects communication failure with DOUT16A. (3s overtime)
61	AIN16-M01 Com Fail	Action when the controller detects communication failure with AIN16-M01. (3s overtime)
62	LA16 Com Fail	Action when the controller detects communication failure with LA16. (3s overtime)
63	ECU Com Fail	Action when the controller detects no ECU connection after ECU powered on.
64	ECU Warn	Action when the controller receives warning alarm from ECU.
65	ECU Shutdown	Action when the controller receives shutdown alarm from ECU.
66	Bat 1 Under Volt	Action when the controller detects that the battery 1 voltage has



		fallen below the set value.
67	Bat 2 Under Volt	Action when the controller detects that the battery 2 voltage has fallen below the set value.
68	Under Speed Warn	Action when under speed warning.
69	Under Speed Shutdown	Action when under speed shutdown alarm.
70	Over Speed Warn	Action when over speed warning.
71	Over Speed Shutdown	Action when over speed shutdown alarm
72	Emergency Stop	Action when emergency stop alarm.
73	Charge Alt Fail	Action when charge alternator failure warning.
74	Reserved	
75	Failed To Start	Action when failed stop alarm.
76	Reserved	
77	Reserved	
78	Sensor 1 Open	Action when sensor 1 is open circuit.
79	Sensor 1 Warn	Action when sensor 1 warning alarm.
80	Sensor 1 Shutdown	Action when sensor 1 shutdown alarm.
81	Sensor 2 Open	Action when sensor 2 is open circuit.
82	Sensor 2 Warn	Action when sensor 2 warning alarm.
83	Sensor 2 Shutdown	Action when sensor 2 shutdown alarm.
84	Sensor 3 Open	Action when sensor 3 is open circuit.
85	Sensor 3 Warn	Action when sensor 3 warning alarm.
86	Sensor 3 Shutdown	Action when sensor 3 shutdown alarm.
87	Sensor 4 Open	Action when sensor 4 is open circuit.
88	Sensor 4 Warn	Action when sensor 4 warning alarm.
89	Sensor 4 Shutdown	Action when sensor 4 shutdown alarm.
90	Sensor 5 Open	Action when sensor 5 is open circuit.
91	Sensor 5 Warn	Action when sensor 5 warning alarm.
92	Sensor 5 Shutdown	Action when sensor 5 shutdown alarm.
93	Sensor 6 Open	Action when sensor 6 is open circuit.
94	Sensor 6 Warn	Action when sensor 6 warning alarm.
95	Sensor 6 Shutdown	Action when sensor 6 shutdown alarm.
96	Sensor 7 Open	Action when sensor 7 is open circuit.
97	Sensor 7 Warn	Action when sensor 7 warning alarm.
98	Sensor 7 Shutdown	Action when sensor 7 shutdown alarm.
99	Sensor 8 Open	Action when sensor 8 is open circuit.
100	Sensor 8 Warn	Action when sensor 8 warning alarm.
101	Sensor 8 Shutdown	Action when sensor 8 shutdown alarm.
102	AIN16-1 Sensor 1 Open (expansion 1)	Action when sensor 1 opening circuit. (expansion 1)
103	AIN16-1 Sensor 1	Action when sensor 1 warning alarm. (expansion 1)



	Warn (expansion 1)	
104	AIN16-1 Sensor 1 Stop (expansion 1)	Action when sensor 1 shutdown alarm. (expansion 1)
105	AIN16-1 Sensor 2 Open (expansion 1)	Action when sensor 2 opening circuit. (expansion 1)
106	AIN16-1 Sensor 2 Warn (expansion 1)	Action when sensor 2 warning alarm. (expansion 1)
107	AIN16-1 Sensor 2 Stop (expansion 1)	Action when sensor 2 shutdown alarm. (expansion 1)
108	AIN16-1 Sensor 3 Open (expansion 1)	Action when sensor 3 opening circuit. (expansion 1)
109	AIN16-1 Sensor 3 Warn (expansion 1)	Action when sensor 3 warning alarm. (expansion 1)
110	AIN16-1 Sensor 3 Stop (expansion 1)	Action when sensor 3 shutdown alarm. (expansion 1)
111	AIN16-1 Sensor 4 Open (expansion 1)	Action when sensor 4 opening circuit. (expansion 1)
112	AIN16-1 Sensor 4 Warn (expansion 1)	Action when sensor 4 warning alarm. (expansion 1)
113	AIN16-1 Sensor 4 Stop (expansion 1)	Action when sensor 4 shutdown alarm. (expansion 1)
114	AIN16-1 Sensor 5 Open (expansion 1)	Action when sensor 5 opening circuit. (expansion 1)
115	AIN16-1 Sensor 5 Warn (expansion 1)	Action when sensor 5 warning alarm. (expansion 1)
116	AIN16-1 Sensor 5 Stop (expansion 1)	Action when sensor 5 shutdown alarm. (expansion 1)
117	AIN16-1 Sensor 6 Open (expansion 1)	Action when sensor 6 opening circuit. (expansion 1)
118	AIN16-1 Sensor 6 Warn (expansion 1)	Action when sensor 6 warning alarm. (expansion 1)
119	AIN16-1 Sensor 6 Stop (expansion 1)	Action when sensor 6 shutdown alarm. (expansion 1)
120	AIN16-1 Sensor 7 Open (expansion 1)	Action when sensor 7 opening circuit. (expansion 1)
121	AIN16-1 Sensor 7 Warn (expansion 1)	Action when sensor 7 warning alarm. (expansion 1)
122	AIN16-1 Sensor 7 Stop (expansion 1)	Action when sensor 7 shutdown alarm. (expansion 1)
123	AIN16-1 Sensor 8 Open (expansion 1)	Action when sensor 8 opening circuit. (expansion 1)
124	AIN16-1 Sensor 8 Warn (expansion 1)	Action when sensor 8 warning alarm. (expansion 1)



125	AIN16-1 Sensor 8 Stop (expansion 1)	Action when sensor 8 shutdown alarm. (expansion 1)
126	AIN16-1 Sensor 9 Open (expansion 1)	Action when sensor 9 opening circuit. (expansion 1)
127	AIN16-1 Sensor 9 Warn (expansion 1)	Action when sensor 9 warning alarm. (expansion 1)
128	AIN16-1 Sensor 9 Stop (expansion 1)	Action when sensor 9 shutdown alarm. (expansion 1)
129	AIN16-1 Sensor 10 Open (expansion 1)	Action when sensor 10 opening circuit. (expansion 1)
130	AIN16-1 Sensor 10 Warn (expansion 1)	Action when sensor 10 warning alarm. (expansion 1)
131	AIN16-1 Sensor 10 Stop (expansion 1)	Action when sensor 10 shutdown alarm. (expansion 1)
132	AIN16-1 Sensor 11 Open (expansion 1)	Action when sensor 11 opening circuit. (expansion 1)
133	AIN16-1 Sensor 11 Warn (expansion 1)	Action when sensor 11 warning alarm. (expansion 1)
134	AIN16-1 Sensor 11 Stop (expansion 1)	Action when sensor 11 shutdown alarm. (expansion 1)
135	AIN16-1 Sensor 12 Open (expansion 1)	Action when sensor 12 opening circuit. (expansion 1)
136	AIN16-1 Sensor 12 Warn (expansion 1)	Action when sensor 12 warning alarm. (expansion 1)
137	AIN16-1 Sensor 12 Stop (expansion 1)	Action when sensor 12 shutdown alarm. (expansion 1)
138	AIN16-1 Sensor 13 Open (expansion 1)	Action when sensor 13 opening circuit. (expansion 1)
139	AIN16-1 Sensor 13 Warn (expansion 1)	Action when sensor 13 warning alarm. (expansion 1)
140	AIN16-1 Sensor 13 Stop (expansion 1)	Action when sensor 13 shutdown alarm. (expansion 1)
141	AIN16-1 Sensor 14 Open (expansion 1)	Action when sensor 14 opening circuit. (expansion 1)
142	AIN16-1 Sensor 14 Warn (expansion 1)	Action when sensor 14 warning alarm. (expansion 1)
143	AIN16-1 Sensor 14 Stop (expansion 1)	Action when sensor 14 shutdown alarm. (expansion 1)
144	AIN16-1 Sensor 15 Open (expansion 1)	Action when sensor 15 opening circuit. (expansion 1)
145	AIN16-1 Sensor 15 Warn (expansion 1)	Action when sensor 15 warning alarm. (expansion 1)
146	AIN16-1 Sensor 15 Stop (expansion 1)	Action when sensor 15 shutdown alarm. (expansion 1)



	Stop (expansion 1)	
147	AIN16-1 Sensor 16 Open (expansion 1)	Action when sensor 16 opening circuit. (expansion 1)
148	AIN16-1 Sensor 16 Warn (expansion 1)	Action when sensor 16 warning alarm. (expansion 1)
149	AIN16-1 Sensor 16 Stop (expansion 1)	Action when sensor 16 shutdown alarm. (expansion 1)
150	DIN16-1 Input 1 Active (expansion 1)	Action when input port 1 is active (expansion 1)
151	DIN16-1 Input 2 Active (expansion 1)	Action when input port 2 is active (expansion 1)
152	DIN16-1 Input 3 Active (expansion 1)	Action when input port 3 is active (expansion 1)
153	DIN16-1 Input 4 Active (expansion 1)	Action when input port 4 is active (expansion 1)
154	DIN16-1 Input 5 Active (expansion 1)	Action when input port 5 is active (expansion 1)
155	DIN16-1 Input 6 Active (expansion 1)	Action when input port 6 is active (expansion 1)
156	DIN16-1 Input 7 Active (expansion 1)	Action when input port 7 is active (expansion 1)
157	DIN16-1 Input 8 Active (expansion 1)	Action when input port 8 is active (expansion 1)
158	DIN16-1 Input 9 Active (expansion 1)	Action when input port 9 is active (expansion 1)
159	DIN16-1 Input 10 Active (expansion 1)	Action when input port 10 is active (expansion 1)
160	DIN16-1 Input 11 Active (expansion 1)	Action when input port 11 is active (expansion 1)
161	DIN16-1 Input 12 Active (expansion 1)	Action when input port 12 is active (expansion 1)
162	DIN16-1 Input 13 Active (expansion 1)	Action when input port 13 is active (expansion 1)
163	DIN16-1 Input 14 Active (expansion 1)	Action when input port 14 is active (expansion 1)
164	DIN16-1 Input 15 Active (expansion 1)	Action when input port 15 is active (expansion 1)
165	DIN16-1 Input 16 Active (expansion 1)	Action when input port 16 is active (expansion 1)
166~180	Reserved	
181	PLC 1	
182	PLC 2	
183	PLC 3	



184	PLC 4	
185	PLC 5	
186	PLC 6	
187	PLC 7	
188	PLC 8	
189	PLC 9	
190	PLC 10	
191	PLC 11	
192	PLC 12	
193	PLC 13	
194	PLC 14	
195	PLC 15	
196	PLC 16	
197	PLC 17	
198	PLC 18	
199	PLC 19	
200	PLC 20	
201	PLC 21	
202	PLC 22	
203	PLC 23	
204	PLC 24	
205	PLC 25	
206	PLC 26	
207	PLC 27	
208	PLC 28	
209	PLC 29	
210	PLC 30	
211	PLC 31	
212	PLC 32	
213	PLC 33	
214	PLC 34	
215	PLC 35	
216	PLC 36	
217	PLC 37	
218	PLC 38	
219	PLC 39	
220	PLC 40	
221~255	Reserved	

▲Note: The name of the output ports 1~14 only can be configured via PC software.

9.3 SENSOR FUNCTIONAL CONFIGURATION

9.3.1 Sensor Configuration

No.	Settings	Contents	Remarks
1	Sensor type	(0-5) 0: Not Used 1: Oil Pressure Sensor 2: Temperature Sensor 3: Fuel Level Sensor 4: GOV Volt Input 5: K type thermocouple	"GOV Volt Input" sensor must be resistance sensor and can be connected via external 1K potentiometer. "K type thermocouple" sensor must be connected via external analog input module.
2	Sensor curve (resistance type)	Curve types list	See 8.3.2/8.3.3/8.3.4 curve lists
3	Alarm speed	(0-200)%	Alarm when the engine speed has exceed the set value.
4	Range (Current type)	(0-6000)kpa	
5	High Shutdown Enable	(0-1) 0: Enable; 1: Disable	
6	High Shutdown Value	(0-6000)	
7	High Shutdown Delay	(0-3600)s	
8	Low Shutdown Enable	(0-1) 0: Enable; 1: Disable	
9	Low Shutdown Value	(0-6000)	
10	Low Shutdown Delay	(0-3600)s	
11	High Warn Enable	(0-1) 0: Enable; 1: Disable	
12	High Warn Value	(0-6000)	
13	High Return Value	(0-6000)	
14	High Warn Delay	(0-3600)s	
15	Low Warn Enable	(0-1) 0: Enable; 1: Disable	
16	Low Warn Value	(0-6000)	
17	Low Return Value	(0-6000)	
18	Low Warn Delay	(0-3600)s	
19	First point X (Resistance)	Resistance type (not PT100)	
20	Second point X (Resistance)	Resistance type (not PT100)	
21	Third point X (Resistance)	Resistance type (not PT100)	
22	Fourth point X (Resistance)	Resistance type (not PT100)	
23	Fifth point X (Resistance)	Resistance type (not PT100)	
24	Sixth point X (Resistance)	Resistance type (not PT100)	
25	Seventh point X (Resistance)	Resistance type (not PT100)	
26	Eighth point X (Resistance)	Resistance type (not PT100)	
27	First point Y (Value)	Resistance type (not PT100)	
28	Second point Y (Value)	Resistance type (not PT100)	
29	Third point Y (Value)	Resistance type (not PT100)	
30	Fourth point Y (Value)	Resistance type (not PT100)	
31	Fifth point Y (Value)	Resistance type (not PT100)	
32	Sixth point Y (Value)	Resistance type (not PT100)	
33	Seventh point Y (Value)	Resistance type (not PT100)	
34	Eighth point Y (Value)	Resistance type (not PT100)	

35	User-defined string	User-defined sensor names	
----	---------------------	---------------------------	--

9.3.2 Temperature Curves

No.	Contents	Range	Description
0	Not Used		
1	PT100		
2	Custom Curve		
3	VDO		
4	CURTIS		
5	VOLVO-EC		
6	DATCON		
7	SGX		
8	SGD		
9	SGH		
10	Reserved		
11	Reserved		
12	Reserved		
13	Reserved		
14	Reserved		
15	Reserved		

▲Note: PT100 Resistance type temperature sensor division value is set as 0.385 (0.385Ω corresponds to 1°C).

9.3.3 Resistance Sensors Pressure Curves

No.	Contents	Range	Description
0	Not Used		
1	Reserved		
2	Custom Curve		
3	VDO 10bar		
4	CURTIS		
5	VOLVO-EC		
6	DATCON 10bar		
7	SGX		
8	SGD		
9	SGH		
10	Reserved		
11	Reserved		
12	Reserved		
13	Reserved		
14	Reserved		
15	Reserved		

▲Note: There is no need to set curve type if the pressure sensor is current type.



9.3.4 Liquid Level Curves

No.	Contents	Range	Description
0	Not used		
1	Reserved		
2	Custom resistance curve		
3	SGD		
4	SGH		
5	Reserved		
6	Reserved		
7	Reserved		
8	Reserved		
9	Reserved		
10	Reserved		
11	Reserved		
12	Reserved		
13	Reserved		
14	Reserved		
15	Reserved		

SmartGen

10 BACK PANEL



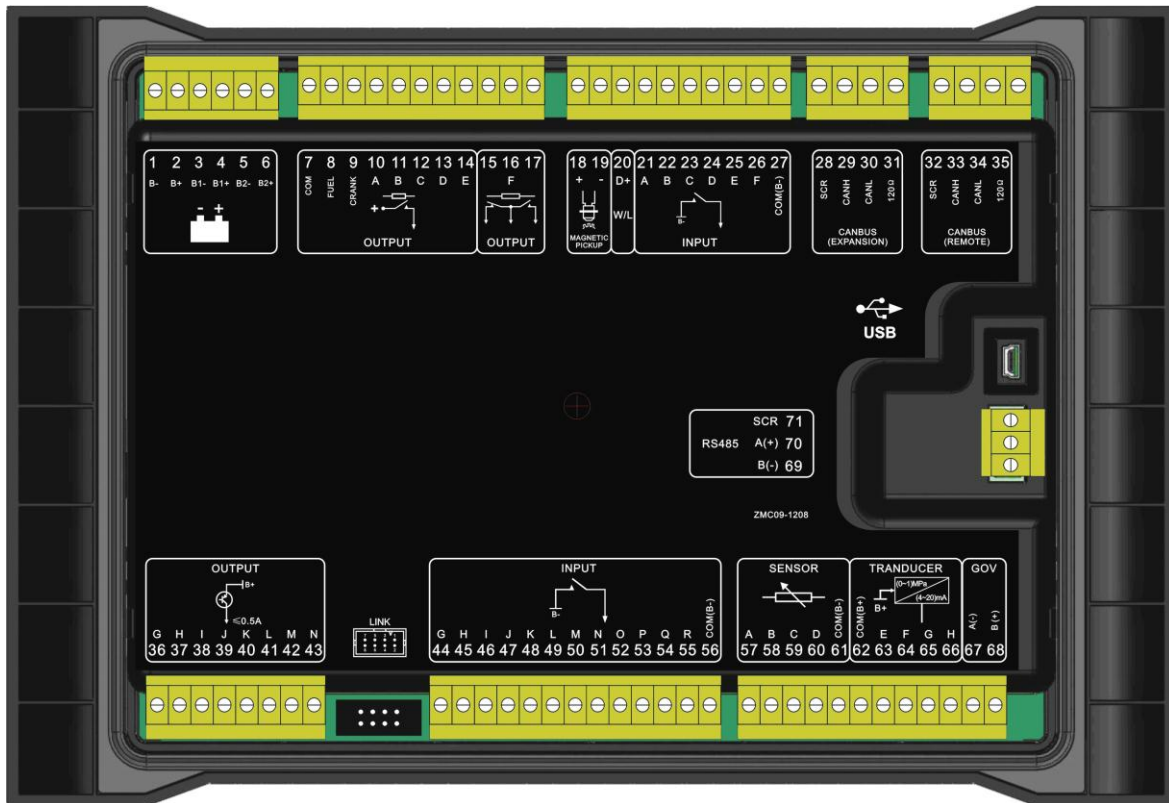

HMC9000 controller back panel layout:

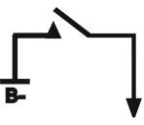

Description of terminal connection:

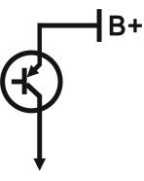
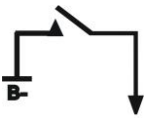
Icon	No.	Function	Cable Size	Description
	1	DC input B-	2.5mm ²	DC power supply negative input. Connected with negative of starter battery.
	2	DC input B+	2.5mm ²	DC power supply negative input. Connected with positive of starter battery.
	3	B1- input	2.5mm ²	Battery 1 voltage input
	4	B1+ input	2.5mm ²	
	5	B2- input	2.5mm ²	Battery 2 voltage input
	6	B2+ input	2.5mm ²	
	7	COM Relay	2.5mm ²	Common relay power supply input
	8	Fuel relay	2.5mm ²	DC power is supplied by 7 terminal, rated 16A. Break wire protection function is fitted.
	9	Start relay	2.5mm ²	DC power is supplied by 7 terminal, rated 16A
	10	Aux. output 1(A)	1.5mm ²	DC power is supplied by 7 terminal, rated 7A. Break wire protection function is fitted (Configurable).
	11	Aux. output 2(B)	1.5mm ²	DC power is supplied by 7 terminal, rated 7A. Break wire protection function is fitted (Configurable).
	12	Aux. output 3(C)	1.5mm ²	DC power is supplied by 7 terminal, rated 7A. Break wire protection function is fitted

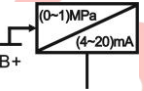
Icon	No.	Function	Cable Size	Description
				(Configurable).
	13	Aux. output 4(D)	1.5mm ²	DC power is supplied by 7 terminal, rated 7A.
	14	Aux. output 5(E)	1.5mm ²	DC power is supplied by 7 terminal, rated 7A.
	15	Aux. output 6(F)	1.5mm ²	Volts Free; Rated current: 7A
	16			
	17			
	18	MP1 (Magnetic pickup+)	1.0mm ²	Speed sensor input.
	19	MP2 (Magnetic pickup-)	1.0mm ²	
D+	20	D+ Charge input	1.0mm ²	Charging generator D+ terminal input; Ground connected is not allowed.
	21	AUX. input 1(A)	1.0mm ²	Digital input; Break wire protection function is fitted (Configurable).
	22	AUX. input 2(B)	1.0mm ²	Digital input; Break wire protection function is fitted (Configurable).
	23	AUX. input 3(C)	1.0mm ²	Digital input; Break wire protection function is fitted (Configurable).
	24	AUX. input 4(D)	1.0mm ²	Digital input; Break wire protection function is fitted (Configurable).
	25	AUX. input 5(E)	1.0mm ²	Digital input; Break wire protection function is fitted (Configurable).
	26	AUX. input 6(F)	1.0mm ²	Digital input; Break wire protection function is fitted (Configurable).
	27	COM(B-)	1.0mm ²	
CANBUS (EXPANSION)	28	SCR (EXPANSION)	0.5mm ²	For ECU module and expansion module connection. Impedance-120Ω shielding wire is recommended, its single-end earthed. There is 120Ω terminal resistance inside already; if needed, make terminal 30, 31 short circuits. (HCM9000E without)
	29	CAN(H) (EXPANSION)		
	30	CAN(L) (EXPANSION)		
	31	120Ω		
CANBUS (REMOTE)	32	SCR (REMOTE)	0.5mm ²	For remote control module connection. Impedance-120Ω shielding wire is recommended, its single-end earthed. There is 120Ω terminal resistance inside already; if needed, make terminal 34, 35 short circuits.
	33	CAN(H) (REMOTE)		
	34	CAN(L) (REMOTE)		
	35	120Ω		
	36	Aux. output 7 (G)	0.5mm ²	B+ voltage output, rated current is 0.5A.
	37	Aux. output 8 (H)	0.5mm ²	B+ voltage output, rated current is 0.5A.
	38	Aux. output 9 (I)	0.5mm ²	B+ voltage output, rated current is 0.5A.

Icon	No.	Function	Cable Size	Description
	39	Aux. output 10(J)	0.5mm ²	B+ voltage output, rated current is 0.5A.
	40	Aux. output 11(K)	0.5mm ²	B+ voltage output, rated current is 0.5A.
	41	Aux. output 12(L)	0.5mm ²	B+ voltage output, rated current is 0.5A.
	42	Aux. output 13(M)	0.5mm ²	B+ voltage output, rated current is 0.5A.
	43	Aux. output 14(N)	0.5mm ²	B+ voltage output, rated current is 0.5A.
	44	Aux. input 7(G)	1.0mm ²	Digital input
	45	Aux. input 8(H)	1.0mm ²	Digital input
	46	Aux. input 9(I)	1.0mm ²	Digital input
	47	Aux. input 10(J)	1.0mm ²	Digital input
	48	Aux. input 11(K)	1.0mm ²	Digital input
	49	Aux. input 12(L)	1.0mm ²	Digital input
	50	Aux. input 13(M)	1.0mm ²	Digital input
	51	Aux. input 14(N)	1.0mm ²	Digital input
	52	Aux. input 15(O)	1.0mm ²	Digital input
	53	Aux. input 16(P)	1.0mm ²	Digital input
	54	Aux. input 17(Q)	1.0mm ²	Digital input
	55	Aux. input 18(R)	1.0mm ²	Digital input
	56	COM(B-) input	1.0mm ²	
	57	AIN1(A)	1.0mm ²	Resistance sensor input
	58	AIN2(B)	1.0mm ²	Resistance sensor input
	59	AIN3(C)	1.0mm ²	Resistance sensor input
	60	AIN4(D)	1.0mm ²	Resistance sensor input
	61	COM(B-) AIN1-4	1.0mm ²	
	62	COM(B+) AIN5-8	1.0mm ²	B+ Power supply output
	63	AIN5(E)	1.0mm ²	4-20mA sensor input
	64	AIN6(F)	1.0mm ²	4-20mA sensor input
	65	AIN7(G)	1.0mm ²	4-20mA sensor input
	66	AIN8(H)	1.0mm ²	4-20mA sensor input
GOV	67	GOV A(-)	1.0mm ²	2 core shielding wire is recommended. Its
	68	GOV B(+)	1.0mm ²	GOV terminal earthed. (HCM9000E without)
RS485	69	RS485(B-)	0.5mm ²	PC programming and monitoring port (isolation type). Its single end earthed.
	70	RS485(A+)	0.5mm ²	
	71	RS485 SCR	0.5mm ²	
USB		USB	0.5mm ²	Enables connection to PC monitoring software

⚠Note: It is strictly prohibited to take out start battery when the engine is running. Failure to do so can create excessive DC input voltage and result in damage or destruction of equipment!

11 TYPICAL WIRING DIAGRAM

HMC9000 Typical Wiring Diagram

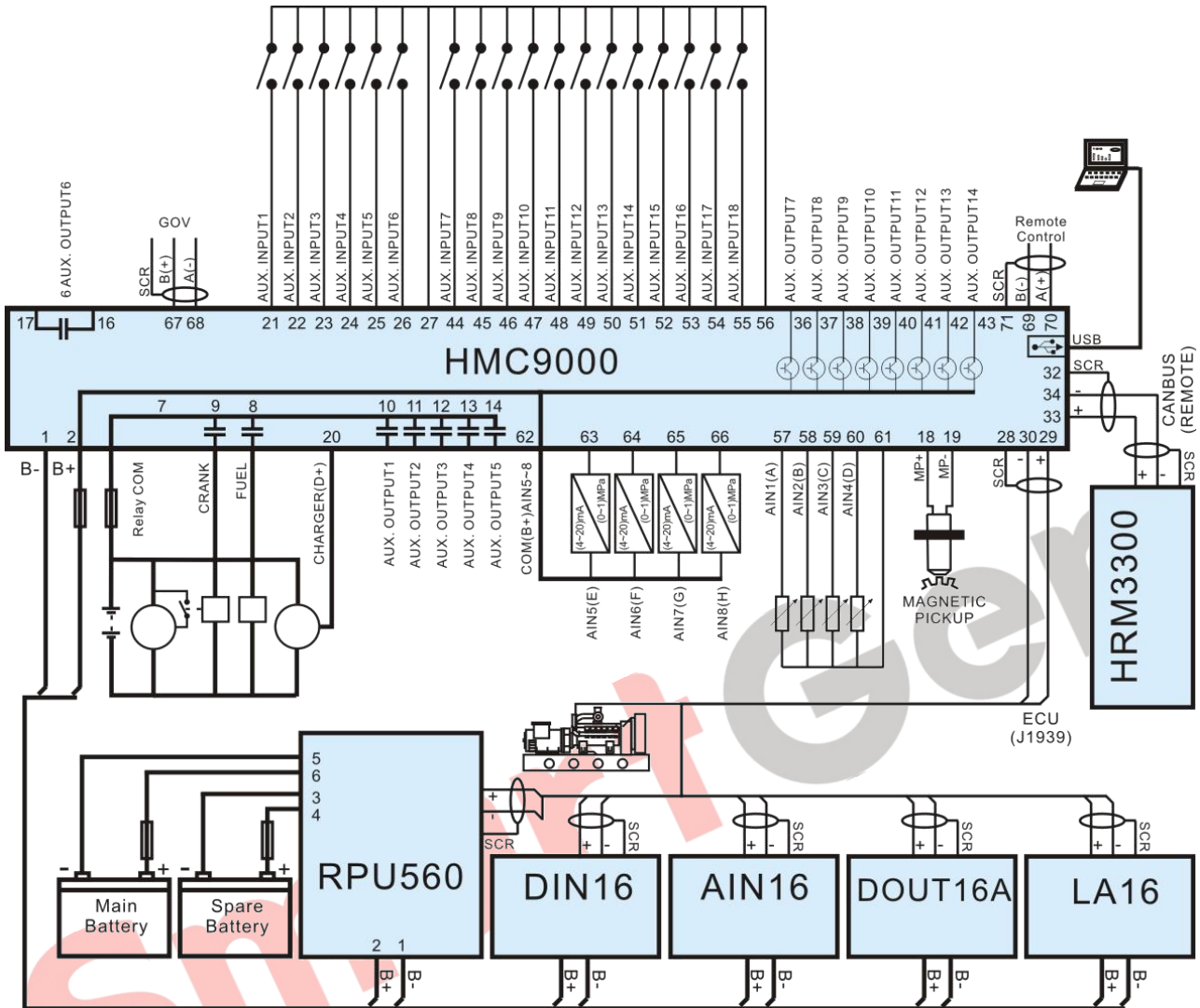

▲Note:

1. Power supply for fuel relay, start relay and auxiliary outputs 1~5 are supplied by terminal 7.
2. To activate battery transfer output you need to connect expansion relay with at least 50A current.

As following:

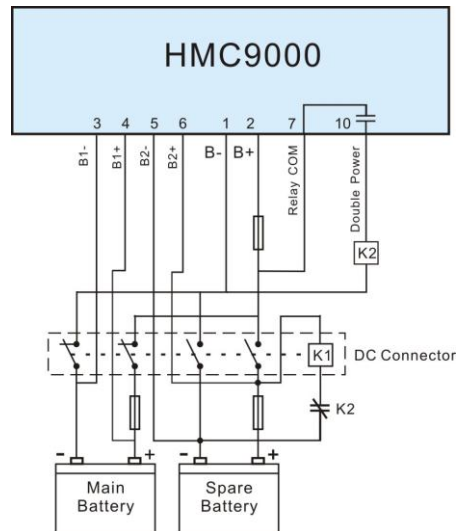

1. Auxiliary outputs 7-14 use transistors (drive current is 0.5A); if you connect external device with current lower than 0.5A, it can be connected directly.
2. Controller expansion modules can only be used together with the main controller; however, the main controller can be used separately.
3. RS485 and USB ports can communicate with PC.
4. Remote modules that have CANBUS and RS485 ports can be connected to REMOTE or RS485 ports for remote control.

12 RS485 COMMUNICATION AND CONNECTION

HMC9000 gen-set controller has RS485 port and USB port which allows the controller to connect to open-type LAN. RS485 and USB applies ModBus communication protocol with the help of PC or DAS (Data Acquisition Systems) operational software provides a simple and useful marine engine monitoring system management scheme and enables remote control, remote measurement and remote communication.

For more information about communication protocols see Smartgen document "HMC9000 communication protocols".

RS485 Communication parameters

Module address	1 (Range: 1~254, user-defined, default: 1)
Baud rate	9600 bps
Data bit	8 bit
Parity check bit	None
Stop bit	2 bit

PC connects to the module's USB as shown below.



13 CONTROLLER AND ENGINES CONNECTION (EXPANSION CANBUS)

A large number of ECU engines can be connected to the EXPANSION port of the controller. Besides, at the same time users can connect expansion module which makes it convenient and suitable for different working environments.

13.1 CUMMINS ISB/ISBE

Terminals of controller	Connector B	Remarks
Fuel relay output	39	
Start relay output	-	Connect to starter coil directly
Auxiliary output port 1	Expand 30A relay, battery voltage of terminal 01,07,12,13 are supplied by relay.	ECU power; set auxiliary output 1 as "ECU power".

Terminals of controller	9 pin connector	Remarks
SCR (EXPANSION)	SAE J1939 shield	CAN communication shielding line (connect to ECU terminal only)
CAN(H) (EXPANSION)	SAE J1939 signal	Impedance 120Ω connecting line is recommended.
CAN(L) (EXPANSION)	SAE J1939 return	Impedance 120Ω connecting line is recommended.

Engine type: **Cummins ISB**

13.2 CUMMINS QSL9

Compatible with CM850 engine controller module.

Terminals of controller	50 pin connector	Remark
Fuel relay output	39	
Start relay output	-	Connect to starter coil directly.

Terminals of controller	9 pin connector	Remark
SCR (EXPANSION)	SAE J1939 shield-E	CAN communication shielding line (connect to ECU terminal only)
CAN(H) (EXPANSION)	SAE J1939 signal-C	Impedance 120Ω connecting line is recommended.
CAN(L) (EXPANSION)	SAE J1939 return-D	Impedance 120Ω connecting line is recommended.

Engine type: **Cummins-CM850**

13.3 CUMMINS QSM11

Compatible with CM750 engine controller module. Engine types: QSM11 G1, QSM11 G2

Terminals of controller	C1 connector	Remark
Fuel relay output	5&8	
Start relay output	-	Connect to starter coil directly.

Terminals of controller	3 pin data link connector	Remark
SCR (EXPANSION)	C	CAN communication shielding line (connect to ECU terminal only)
CAN(H) (EXPANSION)	A	Impedance 120Ω connecting line is recommended.
CAN(L) (EXPANSION)	B	Impedance 120Ω connecting line is recommended.

Engine type: **Cummins ISB**

13.4 DETROIT DIESEL DDEC III / IV

Terminals of controller	Engine CAN port	Remark
Fuel relay output	Expand 30A relay; battery voltage of ECU is supplied by relay	
Start relay output	-	Connect to starter coil directly
SCR (EXPANSION)	-	CAN communication shielding line (connect to controller's terminal only)
CAN(H) (EXPANSION)	CAN(H)	Impedance 120Ω connecting line is recommended.
CAN(L) (EXPANSION)	CAN(L)	Impedance 120Ω connecting line is recommended.

Engine type: **Common J1939**

13.5 DEUTZ EMR2

Terminals of controller	F connector	Remark
Fuel relay output	Expand 30A relay, battery voltage of terminal 14 is supplied by relay. Fuse is 16A.	
Start relay output	-	Connect to starter coil directly
-	1	Connect to battery negative.
SCR (EXPANSION)	-	CAN communication shielding line (connect to controller's terminal only)
CAN(H) (EXPANSION)	12	Impedance 120Ω connecting line is recommended.
CAN(L) (EXPANSION)	13	Impedance 120Ω connecting line is recommended.

Engine type: **Volvo EDC4**

13.6 JOHN DEERE

Terminals of controller	21 pin connector	Remark
Fuel relay output	G, J	
Start relay output	D	
SCR (EXPANSION)	-	CAN communication shielding line (connect to controller's terminal only)
CAN(H) (EXPANSION)	V	Impedance 120Ω connecting line is recommended.
CAN(L) (EXPANSION)	U	Impedance 120Ω connecting line is recommended.

Engine type: **John Deere**

13.7 MTU MDEC

Compatible with MTU 2000 and 4000 series engines.

Terminals of controller	X1 connector	Remark
Fuel relay output	BE1	
Start relay output	BE9	
SCR (EXPANSION)	E	CAN communication shielding line (connect to one of the terminals only)
CAN(H)(EXPANSION)	G	Impedance 120Ω connecting line is recommended.
CAN(L)(EXPANSION)	F	Impedance 120Ω connecting line is recommended.

Engine type: **MTU-MDEC-303**

13.8 PERKINS

Compatible with ADEM3/ ADEM4 engine control modules. Engine types: 2306, 2506, 1106, and 2806.

Terminals of controller	Connector	Remark
Fuel relay output	1,10,15,33,34	
Start relay output	-	Connect to starter coil directly
SCR (EXPANSION)	-	CAN communication shielding line (connect to controller's terminal only)
CAN(H) (EXPANSION)	31	Impedance 120Ω connecting line is recommended.
CAN(L) (EXPANSION)	32	Impedance 120Ω connecting line is recommended.

Engine type: Perkins

13.9 SCANIA

Compatible with S6 engine control module. Engines: DC9, DC12, DC16.

Terminals of controller	B1 connector	Remark
Fuel relay output	3	
Start relay output	-	Connect to starter coil directly
SCR (EXPANSION)	-	CAN communication shielding line (connect to controller's terminal only)
CAN(H) (EXPANSION)	9	Impedance 120Ω connecting line is recommended.
CAN(L) (EXPANSION)	10	Impedance 120Ω connecting line is recommended.

Engine type: Scania

13.10 VOLVO EDC3

Compatible with such engines as TAD1240, TAD1241, and TAD1242.

Terminals of controller	"Stand alone" connector	Remark
Fuel relay output	H	
Start relay output	E	
Auxiliary output 1	P	Set auxiliary output 1 as "Preheating until cranking" and set preheating time as 5 seconds.

Terminals of controller	"Data bus" connector	Remark
SCR (EXPANSION)	-	CAN communication shielding line (connect to controller's terminal only)
CAN(H) (EXPANSION)	1	Impedance 120Ω connecting line is recommended.
CAN(L) (EXPANSION)	2	Impedance 120Ω connecting line is recommended.

Engine type: Volvo

13.11 VOLVO EDC4

Compatible engine types are TD520, TAD520 (optional), TD720, TAD720 (optional), TAD721, and TAD722.

Terminals of controller	Connector	Remark
Fuel relay output	Expand 30A relay, battery voltage of terminal 14 is supplied by relay. Fuse is 16A.	
Start relay output	-	Connect to starter coil directly.
	1	Connect to battery negative.
SCR (EXPANSION)	-	CAN communication shielding line (connect to controller's terminal only)
CAN(H) (EXPANSION)	12	Impedance 120Ω connecting line is recommended.
CAN(L) (EXPANSION)	13	Impedance 120Ω connecting line is recommended.

Engine type: **Volvo EDC4**

13.12 VOLVO-EMS2

Compatible with the following Volvo engines: TAD734, TAD940, TAD941, TAD1640, TAD1641, TAD1642.

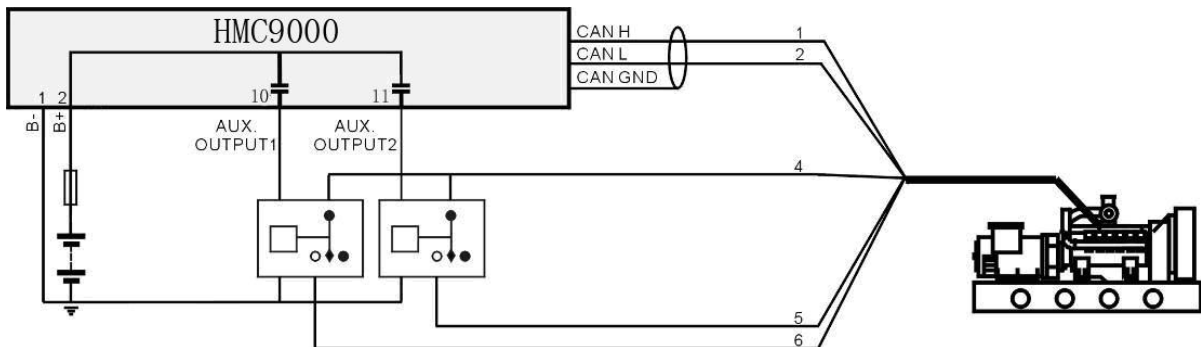

Terminals of controller	Engine CAN port	Remark
Auxiliary output 1	With the help of expansion relay, when auxiliary output 1 is active, relay normally open contact closes, which leads to short circuit of engine 8 pin terminal #4 wire and #6 wire.	Set auxiliary output 1 as "ECU shutdown"
Auxiliary output 2	With the help of expansion relay, when auxiliary output 2 is active, relay normally open contact closes, which leads to short circuit of engine 8 pin terminal #4 wire and #5 wire.	Set auxiliary output 2 as "Preheating until cranking" and set preheating time as 5 seconds.
	3	Power supply negative
	4	Power supply positive
SCR (EXPANSION)	-	CAN communication shielding line (connect to controller's terminal only)
CAN(H) (EXPANSION)	1(Hi)	Impedance 120Ω connecting line is recommended.
CAN(L) (EXPANSION)	2(Lo)	Impedance 120Ω connecting line is recommended.

Engine type: **Volvo-EMS2**

13.13 BOSCH

Compatible with BOSCH common rail electronic engines.

Terminals of controller	42 pin engine port	Remark
Fuel relay output	1.40	Connect to engine ignition switch.
Start relay output	-	Connect to starter coil directly
SCR (EXPANSION)	-	CAN communication shielding line (connect to controller's terminal only)
CAN(H) (EXPANSION)	1.35	Impedance 120Ω connecting line is recommended.
CAN(L) (EXPANSION)	1.34	Impedance 120Ω connecting line is recommended.

Battery	2 pin engine port	Remark
Battery negative	1	Wire size: 2.5mm ²
Battery positive	2	Wire size: 2.5mm ²

Engine type: **BOSCH**

Please contact us if you have any questions about controller and ECU connection.

13.14 EXPANSION MODULES

Various expansion modules can be connected to the controller via EXPANSION port.

1. RPU560A Security module: The module connects to the main controller via CANBUS port. If security module receives no signal from the main controller for more than 1 second and the main controller failure input deactivates, security module will take over engine control; after that the engine will be stopped only by shutdown input or in case of overspeed. Module input function, output function and overspeed alarm threshold are user-set.

2. AIN16 Analog input module: The module is connected to main controller via CANBUS port. The module has 16 input channels, each of which can be set as PT100 or 4~20mA type. Besides, channels 10 and 11 can be set as K-type thermocouple input. All alarm threshold values and measuring ranges can be set via HMC9000 controller and cannot be lost in case of power outage.

3. DIN16 Digital Input Module: The module is connected to main controller via CANBUS port. The module has 16 input channels, each of which can be set via HMC9000 controller. The set parameters can be saved in internal HMC9000 controller and cannot be lost in case of power outage.

4. DOUT16 Digital Output Module: The module is connected to main controller via CANBUS port. The module has 16 output channels, each of which can be set via HMC9000 controller. The set parameters can be saved in internal HMC9000 controller and cannot be lost in case of power outage.

5. LA16 Lamp Expansion Module: The module is connected to main controller via CANBUS port. The module has 16 programmable lamp and there are 3 kinds of color (red, green, yellow) can be chosen, besides, the light brightness can be adjusted. The set parameters can be saved in internal HMC9000 controller and cannot be lost in case of power outage.

6. HRM3300 Remote Control Module: The module is connected to main controller via CANBUS port. It can carry out remote start/stop of the marine genset, alarm mute and other functions. All the parameters and event logs are displayed on the remote control module in real-time.

7. AIN16-C 4-20mA Gathering Module: The module is connected to main controller via CANBUS port. The module has 16 4-20mA input channels, each of which can be set via HMC9000 controller. The set parameters can be saved in internal HMC9000 controller and cannot be lost in case of power outage.

8. AIN16-PT PT100 Gathering Module: The module is connected to main controller via CANBUS port. The module has 16 PT100 input channels, each of which can be set via HMC9000 controller. The set parameters can be saved in internal HMC9000 controller and cannot be lost in case of power outage.

9. AIN16-M01 Analog Input/Output Module: The module is connected to main controller via CANBUS port. The module has 1 4-20mA input channel, 8 PT100 sensor input channels, 3 rotate speed sensor input channels and 1 4-20mA output channels, each of which can be set via HMC9000 controller. The set parameters can be saved in internal HMC9000 controller and cannot be lost in case of power outage.

▲Note: Only in remote mode can remote control module control the engine; in local mode, it can only

monitor the engine, but not control.

14 CONTROL PORT

This expansion port is a CANBUS port for connecting remote control module. Remote control module enables start, stop, alarm mute and other functions to be performed on the distance. All engine parameters and real-time events are displayed on the remote control module.

⚠Note: Remote control module can only be used in remote mode of the engine; in local mode only shutdown button will have effect.

15 INSTALLATION

The front panel of **HMC9000** has embedded structure; the module is fixed with the help of fixing clips. Overall dimensions and cutout dimensions can be seen below.

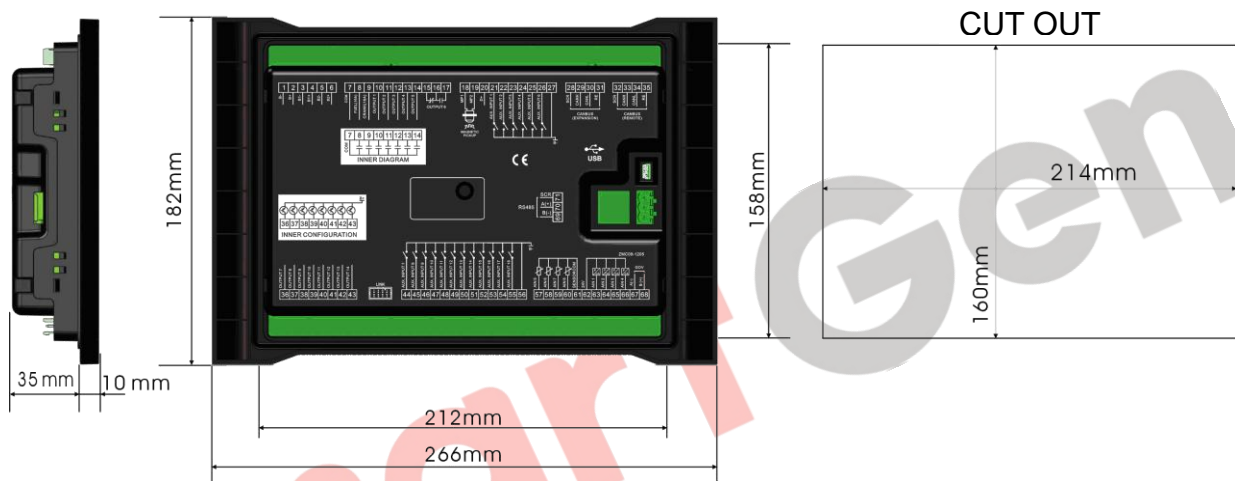

16 TROUBLESHOOTING

Problem	Possible Solution
Controller no response with power.	Check starting batteries; Check controller connection wirings; Check DC fuse.
Genset shutdown	Check the water/cylinder temperature is too high or not; Check DC fuse.
Emergency shutdown	Check emergency shutdown button function is correct or not; Check if start battery positive pole is connected to emergency shutdown input in the right way. Check if there is open circuit in connecting wires.
Low oil pressure alarm after engine has fired.	Check oil pressure sensor and wiring.
High water temperature alarm after engine has fired.	Check water temperature sensor and its wiring.
Shutdown alarm when engine is running	Check relevant switch and its wiring according to the information on LCD. Check auxiliary digital input port.
Fail to start	Check fuel return circuit and its wiring. Check starting battery. Check speed sensor and its wiring. Consult engine manual.
Starter no respond	Check starter wiring; Check start battery
RS485 communication failure	Check wiring; Check if RS485 A and B wires are connected in the opposite way; Check if RS485 transfer module is damaged; Check if PC communication port is damaged.
ECU communication failure or abnormal communication	Check wiring. Check if H and L CANBUS wires are connected in the opposite way; Check if ECU is damaged; Check if the engine type is correct; Check if ECU power output is correct.
Auxiliary input alarm	Check wiring. Check if input polarities configuration is correct.