



**SmartGen**<sup>®</sup>  
ideas for power

## HGM7110VS Genset Controller

### USER MANUAL



ZHENGZHOU SMARTGEN TECHNOLOGY CO.,LTD



Chinese trademark

**SmartGen**<sup>®</sup> English trademark

**Smartgen** — make your generator *smart*

**Smartgen Technology Co., Ltd.**

**No. 28 Jinsuo Road**

**Zhengzhou City**

**Henan Province**

**P. R. China**

**Tel:** +86-371-67988888

+86-371-67981888

+86-371-67991553

+86-371-67992951

+86-371-67981000(overseas)

**Fax:** 0086-371-67992952

**Web:** <http://www.smartgen.com.cn/>

<http://www.smartgen.cn/>

**Email:** [sales@smartgen.cn](mailto:sales@smartgen.cn)

All rights reserved. No part of this publication may be reproduced in any material form (including photocopying or storing in any medium by electronic means or other) without the written permission of the copyright holder.

Smartgen Technology reserves the right to change the contents of this document without prior notice.



If colors of actual products are different from those mentioned within this manual, please take the actual product as the standard.

#### **Version history**

Date	Version	Contents
2014-08-18	1.0	Original release

This manual is suitable for HGM7110VS controller only.

Clarification of notation used within this publication.

SIGN	INSTRUCTION
 Note	Highlights an essential element of a procedure to ensure correctness.
 Caution!	Indicates a procedure or practice, which, if not strictly observed, could result in damage or destruction of equipment.
 Warning!	Indicates error operation may cause death, serious injury and significant property damage.

SmartGen

# Contents

1 OVERVIEW .....	6
2 PERFORMANCE AND CHARACTERISTICS.....	7
3 SPECIFICATION .....	9
4 OPERATION.....	10
4.1 INDICATOR LIGHT .....	10
4.2 PUSHBUTTONS.....	11
4.3 LCD DISPLAY .....	12
4.3.1 MAIN DISPLAY .....	12
4.3.2 PARAMETERS SETTING MENU.....	13
4.4 AUTO START/STOP OPERATION.....	16
4.5 MANUAL START/STOP OPERATION .....	18
4.6 SWITCH CONTROL PROCEDURES.....	19
5 PROTECTIONS .....	20
5.1 WARNING ALARMS.....	20
5.2 SHUTDOWN ALARM .....	22
5.3 TRIP AND STOP ALARM .....	24
5.4 TRIP ALARM .....	25
6 WIRING CONNECTION .....	26
7 SCOPES AND DEFINITIONS OF PROGRAMMABLE PARAMETERS.....	29
7.1. CONTENTS AND SCOPES OF PARAMETERS .....	29
7.2. PROGRAMMABLE OUTPUT PORTS .....	37
7.2.1 DEFINED PERIOD OUTPUT .....	40
7.2.2 DEFINED COMBINATION OUTPUT.....	41
7.3 PROGRAMMABLE INPUT PORTS (ALL ACTIVE WHEN CONNECT TO GRAND (B-)) .....	42
7.4. SELECTION OF SENSORS .....	44
7.5 CONDITIONS OF CRANK DINSCONNECT SELECTION .....	45
8 PARAMETERS SETTING.....	46
9 SENSORS SETTING .....	47
10 COMMISSIONING.....	48
11 TYPICAL APPLICATION.....	49
13.1 GSM SHORT MESSAGE ALARM.....	52
13.2 GSM SHORT MESSAGE REMOTE CONTROL .....	52

14 FAULT FINDING ..... 54

SmartGen

## 1 OVERVIEW

**HGM7110VS** genset controller is used for genset automation and monitor control system of single unit to achieve automatic start/stop, data measure, alarm protection and “three remote” (remote control, remote measuring and remote communication). Controller adjusts engine speed according to genset present power so as to realize energy saving and pollution reduction. The controller adopts large liquid crystal display (LCD) and selectable Chinese, English or other languages interface with easy and reliable operation.

**HGM7110VS** controller adopts 32 bits micro-processor technology with precision parameters measuring, fixed value adjustment, time setting and threshold adjusting and etc. The majority of parameters can be set using front panel and all the parameters can be set using PC (via USB port) and can be adjusted and monitored with the help of RS485 ports. It can be widely used in all types of automatic genset control system with compact structure, advanced circuits, simple connections and high reliability.

SmartGen

## 2 PERFORMANCE AND CHARACTERISTICS

- With ARM-based 32-bit SCM, highly integrated hardware, new reliability level;
- 132x64 LCD with backlight, multilingual interface (including English, Chinese or other languages) which can be chosen at the site, making commissioning convenient for factory personnel;
- Improved LCD wear-resistance and scratch resistance due to hard screen acrylic;
- Silicon rubber panel and pushbuttons for better operation in high/low temperature environment;
- GOV output port enables controller adjusts engine speed according to genset present power so as to realize energy saving and pollution reduction.
- RS485 communication port enables remote control, remote measuring, remote communication via ModBus protocol.
- Equipped with SMS (Short Message Service) function. When genset is alarming, controller can send short messages via SMS automatically to max. 5 telephone numbers. Besides, generator status can be controlled and checked using SMS; Suitable for 3 phase 4 wire, 3 phase 3 wire, single phase 2 wire, 2 phase 3 wire (120/240V) power supply, 50/60Hz system.
- Collects and shows 3-phase voltage, current, power parameter and frequency of generator.

### Generator

Line voltage ( $U_{ab}$ ,  $U_{bc}$ , and  $U_{ca}$ )

Phase voltage ( $U_a$ ,  $U_b$ , and  $U_c$ )

Phase sequence

Frequency Hz

### Load

DC voltage, Current, Power

AC Current IA, IB, IC

Each phase and total active power kW

Each phase and total reactive power kVar

Each phase and total apparent power kVA

Each phase and average power factor PF

Accumulate total generator power kWh, kVarh, kVAh

- Collect and display DC voltage, current and power.
- For generator, controller has over and under voltage, over and under frequency, loss of phase, phase sequence wrong, over and reverse power, over current functions;
- 3 fixed analog sensors (temperature, oil pressure and liquid level);
- 2 configurable sensors can be set as sensor of temperature, oil pressure or fuel level;

- Precision measure and display parameters about Engine,
  - Temp. (WT)                    °C/°F both be displayed
  - Oil pressure (OP)            kPa/Psi/Bar all be displayed
  - Fuel level (FL)                %(unit)
  - Speed (SPD)                  r/min (unit)
  - Voltage of Battery (VB)      V (unit)
  - Voltage of Charger (VD)     V (unit)
- Hour count (HC) can accumulate to max. 65535 hours.
- Start times can accumulate to max. 65535 times.
- Protection: automatic start/stop of the genset, ATS(Auto Transfer Switch) control with perfect fault indication and protection function;
- All output ports are relay-out;
- Parameter setting: parameters can be modified and stored in internal EEPROM memory and cannot be lost even in case of power outage; most of them can be adjusted using front panel of the controller and all of them can be modified using PC via USB or RS485 ports.
- More kinds of curves of temperature, oil pressure, fuel level can be used directly and users can define the sensor curves by themselves;
- Multiple crank disconnect conditions (speed sensor, oil pressure, generator frequency) are optional;
- Widely power supply range DC(8~35)V, suitable to different starting battery voltage environment;
- Event log and real-time clock function;
- Scheduled start & stop generator (can be set as start genset once a day/week/month whether with load or not);
- Selectable configuration: Users can choose different configuration via input port.
- Can be used on pumping units and as an indicating instrument (indicate and alarm are enable only, relay is inhibited );
- With maintenance function. Actions (warning, trip and stop) can be set when maintenance time out;
- All parameters used digital adjustment, instead of conventional analog modulation with normal potentiometer, more reliability and stability;
- Waterproof security level IP55 due to rubber seal installed between the controller enclosure and panel fascia;
- Metal fixing clips enable perfect in high temperature environment;
- Modular design, self-extinguishing ABS plastic enclosure, pluggable connection terminals and embedded installation way; compact structure with easy mounting.



### 3 SPECIFICATION

Parameter	Details
Working Voltage	DC8. 0V to 35. 0V, continuous power supply
Overall Consumption	<3W (Standby mode: ≤2W)
AC Input:	
3 Phase 4 Wire	AC15V ~ AC360V (ph-N)
3 Phase 3 Wire	AC30V ~ AC620V (ph-ph)
Single Phase 2 Wire	AC15V ~ AC360V (ph-N)
2 Phase 3 Wire	AC15V ~ AC360V (ph-N)
Alternator Frequency	50Hz/60Hz
Speed Sensor Voltage	1. 0 V to 24 V (RMS)
Speed Sensor Frequency	Maximum 10,000 Hz
Start Relay Output	16A DC28V power supply output
Fuel Relay Output	16A DC28V power supply output
Configurable Relay Output 1	7A DC28V power supply output
Configurable Relay Output 2	7A AC250V passive output
Configurable Relay Output 3	16A AC250V passive output
Configurable Relay Output 4	16A AC250V passive output
Configurable Relay Output 5	7A DC28V power supply output
Configurable Relay Output 6	7A DC28V power supply output
Case Dimensions	197mm x 152mm x 47mm
Panel Cutout	186mm x 141mm
CT Secondary Current	Rated 5A
Working Conditions	Temperature: (-25~+70)°C Humidity: (20~93)%RH
Storage Conditions	Temperature:(-25~+70)°C
Protection Level	IP55 Gasket
Insulation Intensity	Apply AC2.2kV voltage between high voltage terminal and low voltage terminal; The leakage current is not more than 3mA within 1min.
Weight	0.75kg

## 4 OPERATION

### 4.1 INDICATOR LIGHT

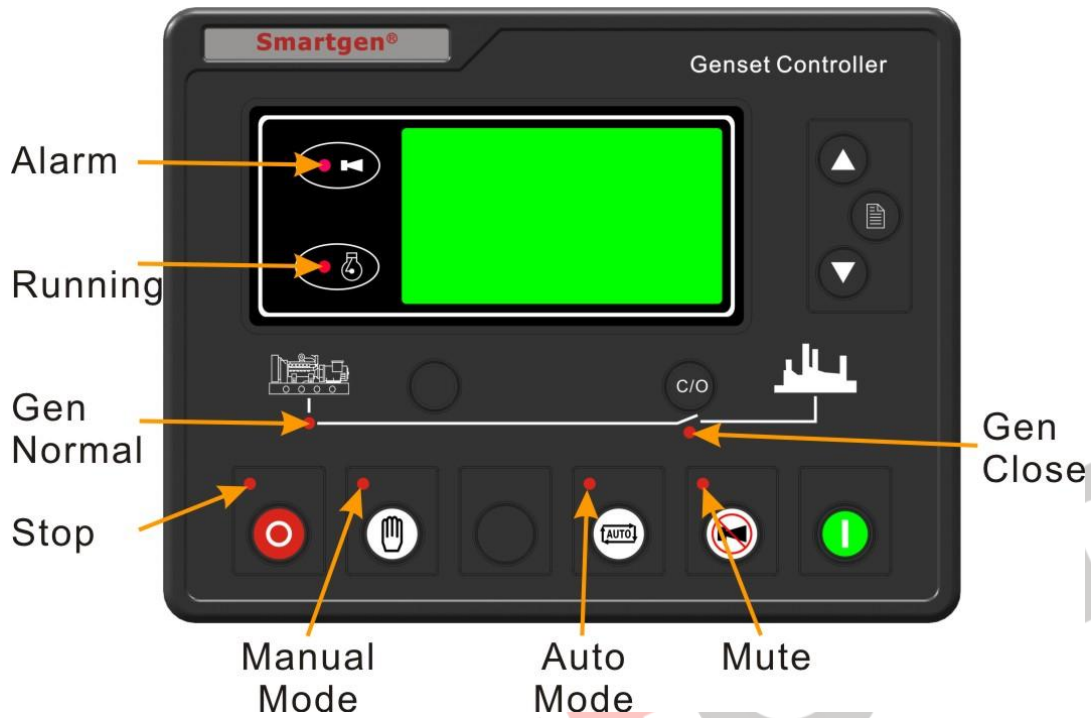

▲NOTE: Selected light indicators description:









Alarm indicator:

Alarm Type	Alarm Indicator
Warning	Slow flashing (1time per sec)
Trip Alarm	Slow flashing (1 time per sec)
Shutdown Alarm	Fast flashing (5 times per sec)
Trip and Stop Alarm	Fast flashing (5 times per sec)





Running indicator: illuminated from crank disconnect to ETS while off during other periods.

Gen normal indicator: It is illuminated when generator is normal; flashing when generator state is abnormal; off when there is no generator power.

## 4.2 PUSHBUTTONS

	Stop	Stop running generator in Auto/Manual mode; Lamp test (press at least 3 seconds); Reset alarm in stop mode; During stopping process, press this button again to stop generator immediately.
	Start	Start genset in Manual/Test mode.
	Manual Mode	Press this key and controller enters in Manual mode.
	Auto Mode	Press this key and controller enters in Auto mode.
	Mute/Reset Alarm	Alarming sound off; If there is trip alarm, pressing the button at least 3 seconds can reset this alarm.
	Gen Close/Open	Can control generator to switch on or off in Manual mode.
	Page Scroll/Confirm	1) Page turning; 2) Press it at least 3 seconds to enters in basic parameter setting menu and shift cursor to confirm the set information.
	Up/Increase	1) Screen scroll; 2) Up cursor and increase value in setting menu.
	Down/Decrease	1) Screen scroll; 2) Down cursor and decrease value in setting menu.



**NOTE:** Pressing and holding  for more than 3 seconds can enter into parameters setting menu.

**NOTE:** Pressing  and  simultaneously will increase LCD contrast; Pressing  and  simultaneously will decrease LCD contrast; When controller is powered on after outage, LCD contrast will return factory default.

**WARNING:**  Default password is 00318, user can change it in case of others change the advanced parameters setting. Please clearly remember the password after changing. If you forget it, please contact Smartgen services and send all information in the controller page of “ABOUT” to us.

## 4.3 LCD DISPLAY

### 4.3.1 MAIN DISPLAY

Main screen show pages; use  to scroll the pages and  to scroll the screen.

★**Main Screen**, including as below,

Genset: voltage, current, frequency, speed

★**Status**, including as below,

Status of genset and ATS

★**Engine**, including as below,

Speed, engine temperature, engine oil pressure, liquid (fuel) level, Configure Sensor 1,

Configure Sensor 2, battery voltage, charger voltage, accumulated run time, accumulated start times.

★**Gen**, including as below,

Phase voltage, Line voltage, frequency, phase sequence

★**Load**, including as below,

DC current, voltage, power, AC current, each phase and total active power (positive and negative), each phase and total reactive power (positive and negative), each phase and total apparent power, each phase and average power factor (positive and negative) and accumulated energy (kWh, kVarh, kVAh).

▲**NOTE:** Power factor shows as following,

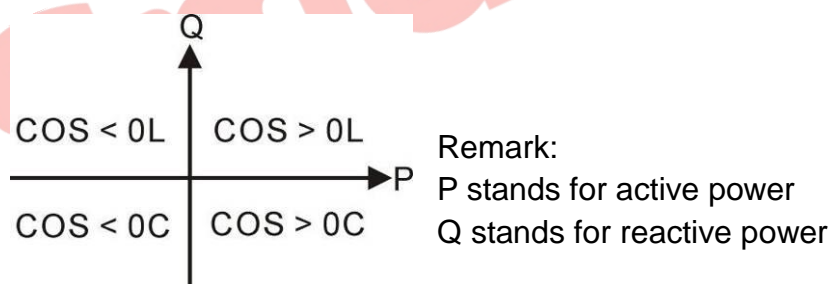

Power factor	Conditions	Active power	Reactive power	Remark
COS>0L	P>0,Q>0	Input	Input	Load is inductive resistance.
COS>0C	P>0,Q<0	Input	Output	Load is capacitance resistance.
COS<0L	P<0,Q>0	Output	Input	Load is equal to one under excitation generator.
COS<0C	P<0,Q<0	Output	Output	Load is equal to one over excitation generator.

▲**Note:**

1. Input active power, generator send active power to load.

2. Output active power, load supply electricity to generator.
3. Input reactive power, generator send reactive power to load.
4. Output reactive power, load send reactive power to generator.

★**Alarm:**

★**Event log**

Records all start/stop events (shutdown alarm, trip and stop alarm, manual /auto start or stop) and the real time when alarm occurs.

**Others**, including,

Time and Date, maintenance due, input/output ports status.

★**About**, including,

Issue time of software and hardware version

Example:

Engine Speed	Gen Volts
1500r/min	L1-N 0V
	L2-N 0V
	L3-N 0V

#### 4.3.2 PARAMETERS SETTING MENU

Parameters setting including as following,

- ★Timer settings
- ★Engine settings
- ★Generator settings
- ★Load settings
- ★ATS settings
- ★Analog sensor settings
- ★Input port settings
- ★output port settings
- ★Module settings
- ★Scheduling and maintenance settings
- ★GSM settings
- ★GOV settings

Example:

Advanced Parameters >Timer >Engine <b>&gt;Generator</b> >Load	Form1: Use   to scroll settings,  to enter settings (form 2), to exit settings menu.
---	--

Generator >Return <b>&gt;AC System</b> >Poles >Rated Voltage	Form 2: Use   to scroll settings (form 3); select "return" and press  to return to previous menu (form 1), or press to return to previous menu (form 1).
--	---





Generator > Under Volt Shutdown > Over Freq Shutdown > Under Freq Shutdown <b>&gt; Over Volt Warn</b>	Form 3: Use   to scroll settings,  to enter settings (form 4), to return to previous menu. (form 1)
---	---

Gen Over Volt Warn Sel: Disable Set Value: 00110% Return Value: 00108% Delay: 00005	Form 4: Use  to enter settings (form 5),   to return to previous menu (form 3),  to return to previous menu. (form 3)
---	--

Gen Over Volt Warn <b>Sel: Disable</b> Set Value: 00110% Return Value: 00108% Delay: 00005	Form 5: Use   to scroll settings(form 6),  to enter settings (form 7),  to exit settings menu. (form 4)
--	---

Gen Over Volt Warn <b>Sel: Enable</b> Set Value: 00110% Return Value: 00108% Delay: 00005	Form 6: Use   to scroll settings(form 5),  to enter settings (form 7),  to exit settings menu. (form 4)
---	---

Gen Over Volt Warn Sel: Enable Set Value: <input type="text" value="00110%"/> Return Value: 00108% Delay: 00005	Form 7: Use   to scroll settings(form 5),  to enter settings, to exit settings menu. (form 4)
---	---

<p>Gen Over Volt Warn Sel: Disable Set Value: 00110% Return Value: 00108% Delay: 00005</p>	<p>Form 8: Use   to scroll settings,  to enter settings (form 4),  to exit settings menu. (form 4)</p>
--	--

 **NOTE:** Long time pressing  can exit setting directly during setting.

SmartGen

## 4.4 AUTO START/STOP OPERATION

Auto mode is selected by pressing the  button; a LED besides the button will illuminate to confirm the operation.

### Starting Sequence:

1. When “Remote Start (with load)” is active, “Start Delay” timer is initiated.
2. “Start Delay” countdown will be displayed on LCD display;
3. When start delay is over, preheat relay energizes (if configured), “preheat delay XXs” information will be displayed on LCD display;
4. After the above delay, the Fuel Relay (if configured) is energized, and then one second later, the Start Relay is engaged. The engine is cranked for a pre-set time. If the engine fails to fire during this cranking attempt then the fuel relay and start relay are disengaged for the pre-set rest period; “crank rest time” begins and wait for the next crank attempt.
5. Should this start sequence continue beyond the set number of attempts, the start sequence will be terminated, and Fail to Start fault will be displayed on LCD display.
6. In case of successful crank attempt, the “Safety On” timer is activated, allowing Low Oil Pressure, High Temperature, Under speed and Charge Alternator Failure inputs to stabilise without triggering the fault. As soon as this delay is over, “start idle” delay is initiated (if configured).
7. During “start idle” delay, under speed, under frequency, under voltage alarms are inhibited. When this delay is over, “warming up” delay is initiated (if configured).
8. After the “warming up” delay, if generator status is normal, its indicator will be illuminated. If generator voltage and frequency have reached on-load requirements, then the generator close relay will be energized; genset will take load; generator power indicator will illuminate and generator will enter into Normal Running status. If voltage or frequency is abnormal, the controller will initiate shutdown alarm (alarm information will be displayed on LCD display).

▲ **Note:** When started via “Remote Start (off Load)” input, same procedures as above but generator close relay deactivated, moreover, genset off load in procedure 8.

### Automatic Stop Sequence,





- 1) When the “Remote Start” signal is removed, the Stop Delay is initiated.
- 2) Once this “stop delay” has expired, the Generator Breaker will open and the “Cooling Delay” is then initiated. Generator power indicator will extinguish.
- 3) During “Stop Idle” Delay (if configured), idle relay is energized.



- 4) "ETS Solenoid Hold" begins, ETS relay is energized while fuel relay is de-energized, complete stop is detected automatically.
- 5) "Fail to Stop Delay" begins, complete stop is detected automatically.
- 6) When generator is stop completely, "After stop" delay will be initiated. Otherwise, fail to stop alarm is initiated and the corresponding alarm information is displayed on LCD display. (If generator is stop successfully after "fail to stop" alarm has initiated, "After stop" delay will be initiated and the alarm will be removed).
- 7) Generator is placed into its standby mode after its "After stop" delay.

SmartGen

## 4.5 MANUAL START/STOP OPERATION

- 1 Manual mode is selected by pressing the  button; a LED besides the button will illuminate to confirm the operation; Then press  button to start the generator, it can automatically judge crank success and accelerate to high speed running. If high temperature, low oil pressure, over speed and abnormal voltage occur during genset running, controller can effectively protect genset to stop (detail procedures please refer to No.3~8 of Auto Start Sequence). In “manual mode ”, the procedures of ATS please refer to Switch Control Procedure of generator in this manual.
- 2 Manual stop: pressing  key can shut down the running genset. (detail procedures please refer to No.2~7 of **Auto Stop Sequence**)

SmartGen

## 4.6 SWITCH CONTROL PROCEDURES

### MANUAL TRANSFER PROCEDURES:

When controller is in **Manual** mode, the switch control procedures will start through manual transfer procedures.

Users can control the loading transfer of ATS via pressing  button to switch on or off.

Press generator switch on key , if generator have taken load, will output unload signal; if taken no load, generator will output load signal.

### AUTO TRANSFER PROCEDURES:

When controller is in AUTO/TEST/STOP mode, auto control will be executive.

#### 1. If input port is configured as Close Generator Auxiliary

##### ◆ If “Open breaker detect” is “SELECT Enable”

Generator load is transferred into generator un-load, after the open delay; switch off signal will be output while “fail to transfer” delay will be initiated. Once the delay has expired, if switch off failed, it will wait for switch off. Otherwise, switch off is completed.

Generator unload is transferred into generator load, after the close delay, switch on signal will be output while “fail to transfer” delay will be initiated. Once the delay has expired, if switch on failed, it will wait for switch on. Otherwise, switch on is completed.

If “fail to transfer” warn is “Enable”, alarm signal will be initiated whatever switch on or off failure.

##### ◆ If “Open breaker detect” is “SELECT Disable”

Generator load is transferred into generator unload, after the open delay, switch off is completed.

Generator unload is transferred into generator load, after the close delay, switch on signal will be output while “fail to transfer” delay will be initiated. Once the delay has expired, if switch on failed, it will wait for switch on. Otherwise, switch on is completed.

If “fail to transfer” warn is “Enable”, alarm signal will be initiated f switch on failure.

#### 2. If input port is **NOT** configured as Close Generator Auxiliary

Generator un-load is transferred into generator load, close generator output.

Generator load is transferred into generator un-load, open generator output.

## 5 PROTECTIONS

### 5.1 WARNING ALARMS

Warnings are not shutdown alarms and do not affect the operation of the gen-set. Warning alarms does not lead to shutdown. Warning alarms types are as follows:

No.	Type	Description
1	Over Speed	When the controller detects that the engine speed has exceeded the pre-set value, it will initiate a warning alarm.
2	Under Speed	When the controller detects that the engine speed has fallen below the pre-set value, it will initiate a warning alarm.
3	Loss of Speed Signal	When the controller detects that the engine speed is 0 and the action select "Warn", it will initiate a warning alarm.
4	Gen Over Frequency	When the controller detects that the genset frequency has exceeded the pre-set value, it will initiate a warning alarm.
5	Gen Under Frequency	When the controller detects that the genset frequency has fallen below the pre-set value, it will initiate a warning alarm.
6	Gen Over Voltage	When the controller detects that the generator voltage has exceeded the pre-set value, the controller will initiate a warning alarm.
7	Genset Under Voltage	When the controller detects that the genset voltage has fallen below the pre-set value, it will initiate a warning alarm.
8	Gen Over Current	When the controller detects that the genset current has exceeded the pre-set value and the action select "Warn", it will initiate a warning alarm.
9	Fail To Stop	After "fail to stop" delay, if gen-set does not stop completely, it will initiate a warning alarm.
10	Charge Alternator Failure	When the controller detects that charger voltage has fallen below the pre-set value, it will initiate a warning alarm.
11	Battery Over Volt	When the controller detects that start battery voltage has exceeded the pre-set value, it will initiate a warning alarm.
12	Battery Under Volt	When the controller detects that start battery voltage has fallen below the pre-set value, it will initiate a warning alarm.
13	Maintenance Due	When count down time is 0 and the action select "Warn", it will initiate a warning alarm.
14	Reverse Power	If reverse power detection is enabled, when the controller detects that the reverse power value (power is negative) has fallen below the pre-set value and the action select "Warn", it will initiate a warning alarm.
15	Over Power	If over power detection is enabled, when the controller detects that the over power value (power is positive) has exceeded the pre-set value and the action select "Warn", it will initiate a warning alarm.
16	Gen Loss of Phase	If loss of phase detection is enabled, When controller detects the generator loss phase, it will initiate a warning alarm.
17	Gen Phase Sequence Wrong	When the controller detects a phase rotation error, it will initiate a warning alarm.
18	Switch Fail Warn	When the controller detects that the breaker close or open failure occurs, and the action select "Warn", it will initiate a

No.	Type	Description
		warning alarm.
19	Temperature Sensor Open Circuit	When the controller detects that the temperature sensor is open circuit and the action select "Warn", it will initiate a warning alarm.
20	High Temperature	When the controller detects that engine temperature has exceeded the pre-set value, it will initiate a warning alarm.
21	Low Temperature	When the controller detects that engine temperature has fallen below the pre-set value, it will initiate a warning alarm.
22	Oil Pressure Open Circuit	When the controller detects that the oil pressure sensor is open circuit and the action select "Warn", it will initiate a warning alarm.
23	Low Oil Pressure	When the controller detects that the oil pressure has fallen below the pre-set value, it will initiate a warning alarm.
24	Level Sensor Open Circuit	When the controller detects that the level sensor is open circuit and the action select "Warn", it will initiate a warning alarm.
25	Low Fuel Level	When the controller detects that the fuel level has fallen below the pre-set value, it will initiate a warning alarm.
26	Flexible Sensor 1 Open Circuit	When the controller detects that the flexible sensor 1 is open circuit and the action select "Warn", it will initiate a warning alarm.
27	Flexible Sensor 1 High	When the controller detects that the sensor 1 value has exceeded the pre-set value, it will initiate a warning alarm.
28	Flexible Sensor 1 Low	When the controller detects that the sensor 1 value has fallen below the pre-set value, it will initiate a warning alarm.
29	Flexible Sensor 2 Open Circuit	When the controller detects that the flexible sensor 2 is open circuit and the action select "Warn", it will initiate a warning alarm.
30	Flexible Sensor 2 High	When the controller detects that the sensor 2 value has exceeded the pre-set value, it will initiate a warning alarm.
31	Flexible Sensor 2 Low	When the controller detects that the sensor 2 value has fallen below the pre-set value, it will initiate a warning alarm.
32	Digital Input	When digit input port is set as warning and the alarm is active, it will initiate a warning alarm.
33	GSM COM Failure	When GSM is enable but the controller couldn't detect GSM module, it will initiate a warning alarm.

## 5.2 SHUTDOWN ALARM

When controller detects shutdown alarm, it will send signal to open breaker and shuts down generator.

Shutdown alarms as following:

No.	Type	Description
1	Emergency Stop	When the controller detects an emergency stop alarm signal, it will initiate a shutdown alarm.
2	Over Speed	When the controller detects that the generator speed has exceeded the pre-set value, it will initiate a shutdown alarm.
3	Under Speed	When the controller detects that the generator speed has fallen below the pre-set value, it will initiate a shutdown alarm.
4	Loss of Speed Signal	When the controller detects that the engine speed is 0 and the action select "Shutdown", it will initiate a shutdown alarm.
5	Gen Over Frequency	When the controller detects that the genset frequency has exceeded the pre-set value, it will initiate a shutdown alarm.
6	Gen Under Frequency	When the controller detects that the genset frequency has fallen below the pre-set value, it will initiate a shutdown alarm.
7	Gen Over Voltage	When the controller detects that the generator voltage has exceeded the pre-set value, the controller will initiate a shutdown alarm.
8	Gen Under Voltage	When the controller detects that the genset voltage has fallen below the pre-set value, it will initiate a shutdown alarm.
9	Fail To Start	If the engine does not fire after the pre-set number of attempts, it will initiate a shutdown alarm.
10	Gen Over Current	When the controller detects that the genset current has exceeded the pre-set value and the action select "Shutdown", it will initiate a shutdown alarm.
11	Maintenance Due	When count down time is 0 and the action select "Shutdown", it will initiate a shutdown alarm.
12	Reverse Power	If reverse power detection is enabled, when the controller detects that the reverse power value (power is negative) has fallen below the pre-set value and the action select "Shutdown", it will initiate a shutdown alarm.
13	Over Power	If over power detection is enabled, when the controller detects that the over power value (power is positive) has exceeded the pre-set value and the action select "Shutdown", it will initiate a shutdown alarm.
14	Temperature Sensor Open Circuit	When the controller detects that the temperature sensor is open circuit and the action select "Shutdown", it will initiate a shutdown alarm.
15	High Temperature	When the controller detects that engine temperature has exceeded the pre-set value, it will initiate a shutdown alarm.
16	Oil Pressure Open Circuit	When the controller detects that the oil pressure sensor is open circuit and the action select "Shutdown", it will initiate a shutdown alarm.
17	Low Oil Pressure	When the controller detects that the oil pressure has fallen below the pre-set value, it will initiate a shutdown alarm.

No.	Type	Description
18	Level Sensor Open Circuit	When the controller detects that the level sensor is open circuit and the action select "Shutdown", it will initiate a shutdown alarm.
19	Flexible Sensor 1 Open Circuit	When the controller detects that the flexible sensor 1 is open circuit and the action select "Shutdown", it will initiate a shutdown alarm.
20	Flexible Sensor 1 High	When the controller detects that the sensor 1 value has exceeded the pre-set value, it will initiate a shutdown alarm.
21	Flexible Sensor 1 Low	When the controller detects that the sensor 1 value has fallen below the pre-set value, it will initiate a shutdown alarm.
22	Flexible Sensor 2 Open Circuit	When the controller detects that the flexible sensor 2 is open circuit and the action select "Shutdown", it will initiate a shutdown alarm.
23	Flexible Sensor 2 High	When the controller detects that the sensor 2 value has exceeded the pre-set value, it will initiate a shutdown alarm.
24	Flexible Sensor 2 Low	When the controller detects that the sensor 2 value has fallen below the pre-set value, it will initiate a shutdown alarm.
25	Digital Input	When digit input port is set as shutdown and the alarm is active, it will initiate a shutdown alarm.

### 5.3 TRIP AND STOP ALARM

On initiation of the trip and stop condition the controller will de-energize the ‘Close Generator’ Output to remove the load from the generator. Once this has occurred the controller will start the Cooling delay and allow the engine to cool before shutting down the engine.

No.	Type	Description
1	Gen Over Current	When the controller detects that the genset current has exceeded the pre-set value and the action select “Trip and Stop”, it will initiate a trip and stop alarm.
2	Maintenance Due	When count down time is 0 and the action select “Trip and Stop”, it will initiate a trip and stop alarm.
3	Reverse Power	If reverse power detection is enabled, when the controller detects that the reverse power value (power is negative) has fallen below the pre-set value and the action select “Trip and Stop”, it will initiate a trip and stop alarm.
4	Over Power	If over power detection is enabled, when the controller detects that the over power value (power is positive) has exceeded the pre-set value and the action select “Trip and Stop”, it will initiate a trip and stop alarm.
5	Digital Input	When digit input port is set as “Trip and Stop” and the alarm is active, it will initiate a trip and stop alarm.



## 5.4 TRIP ALARM

On initiation of the trip condition the controller will de-energize the 'Close Generator' Output without stop the generator.

Trip alarm as following,

No.	Type	Description
1	Gen Over Current	When the controller detects that the genset current has exceeded the pre-set value and the action select "Trip", it will initiate a trip alarm.
2	Reverse Power	If reverse power detection is enabled, when the controller detects that the reverse power value (power is negative) has fallen below the pre-set value and the action select "Trip", it will initiate a trip alarm.
3	Over Power	If over power detection is enabled, when the controller detects that the over power value (power is positive) has exceeded the pre-set value and the action select "Trip", it will initiate a trip alarm.
4	Digital Input	When digit input port is set as "Trip" and the alarm is active, it will initiate a trip alarm.

## 6 WIRING CONNECTION

HGM7110VS controller's rear as following:

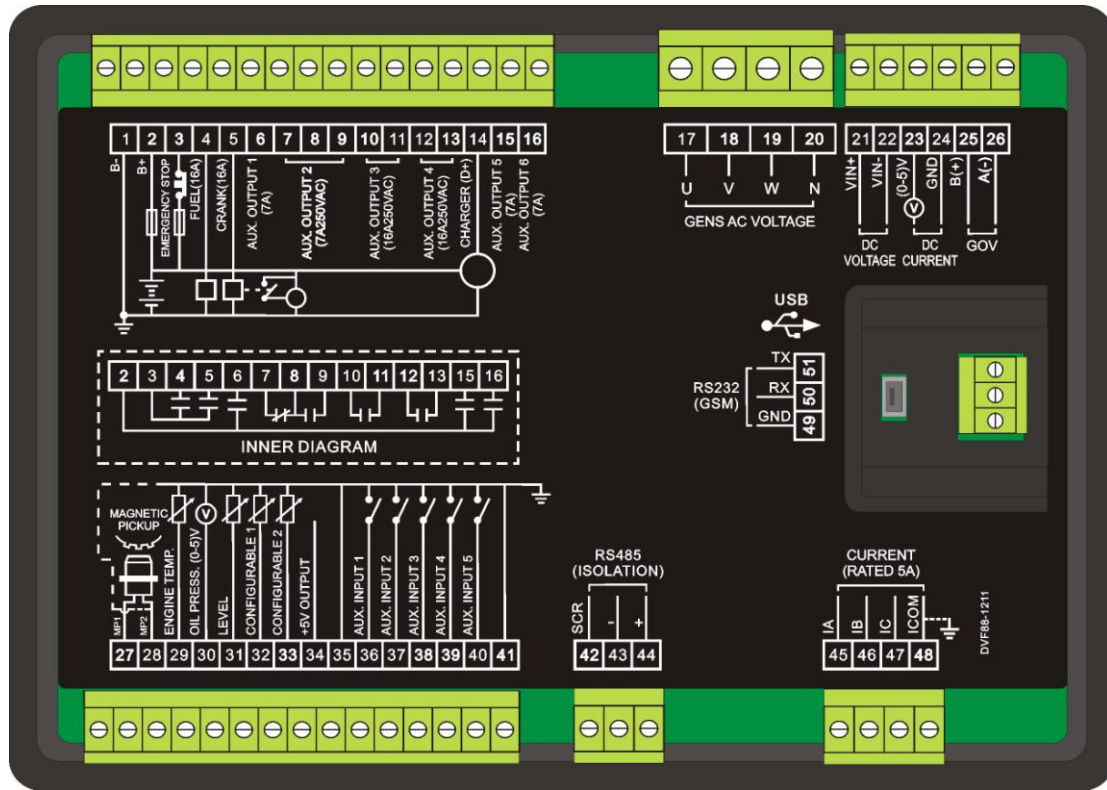

Description of terminal connection:

NO.	Functions	Cable Size	Remark	
1	DC Input -Ve	2.5mm <sup>2</sup>	Connected with negative of starter battery.	
2	DC Input +Ve	2.5mm <sup>2</sup>	Connected with positive of starter battery. If wire length is over 30m, better to double wires in parallel. Max. 20A fuse is recommended.	
3	Emergency Stop	2.5mm <sup>2</sup>	Connected with +Ve via emergency stop button.	
4	Fuel (16A)	1.5mm <sup>2</sup>	+Ve is supplied by terminal 3, rated 16A	
5	Crank (16A)	1.5mm <sup>2</sup>	+Ve is supplied by terminal 3, rated 16A	Connected to starter coil
6	Aux. Output 1	1.5mm <sup>2</sup>	+Ve is supplied by terminal 2, rated 7A	Details see form 2
7	Aux. Output 2	1.5mm <sup>2</sup>	Normally close outputs, rated 7A	
8			Public points of relay	
9			Normally open outputs, rated 7A	
10	Aux. Output 3	2.5mm <sup>2</sup>	Normally open outputs; volts free; rated 16A	
11				
12				
13	Aux. Output 4	2.5mm <sup>2</sup>		
14	Charger (D+)	1.0mm <sup>2</sup>	Connected with charger's D+ (WL) terminals. Be hanging in the air If there is no this terminal.	

NO.	Functions	Cable Size	Remark	
15	Aux. Output 5	1.5mm <sup>2</sup>	+Ve is supplied by terminal 2, rated 7A Details see form 2	
16	Aux. Output 6	1.5mm <sup>2</sup>		
17	Gens Voltage-U AC	1.0mm <sup>2</sup>	Connected to A-phase of genset (2A fuse is recommended).	
18	Gens Voltage-V AC	1.0mm <sup>2</sup>	Connected to B-phase of genset (2A fuse is recommended).	
19	Gens Voltage-W AC	1.0mm <sup>2</sup>	Connected to C-phase of genset (2A fuse is recommended).	
20	Gens Voltage-N AC	1.0mm <sup>2</sup>	Connected to N-wire of gen-set.	
21	VIN+	1.0mm <sup>2</sup>	Connected to DC voltage sampling	
22	VIN-	1.0mm <sup>2</sup>		
23	DC Current (+)	1.0mm <sup>2</sup>	Connected to DC current sensor	
24	DC Current (-)	1.0mm <sup>2</sup>		
25	GOV B(+)	0.5mm <sup>2</sup>	Shielding line is recommended. Shielding layer connect to earth at GOV end.	
26	GOV A(-)	0.5mm <sup>2</sup>		
27	MP1	1.0mm <sup>2</sup>	Connected with Speed sensor, shielding line is recommended.	
28	MP2, (-Ve) has already connected internal	1.0mm <sup>2</sup>		
29	Engine Temp.	1.0mm <sup>2</sup>	Connect to temperature Sensor.	Details see form 4
30	Oil Pressure	1.0mm <sup>2</sup>	Connect to oil pressure sensor.	
31	Fuel Level	1.0mm <sup>2</sup>	Connect to fuel level sensor.	
32	Config. Sensor 1	1.0mm <sup>2</sup>	Connect to temperature sensor, oil pressure sensor or fuel level sensor.	
33	Config. Sensor 2	1.0mm <sup>2</sup>		
34	+5V OUTPUT	1.0mm <sup>2</sup>	Power supply for sensor(current < 50mA)	
35	Sensor COM	1.0mm <sup>2</sup>	A common terminal of sensor, (-Ve) has already connected internal.	
36	Aux. Input 1	1.0mm <sup>2</sup>	Ground connected is active (-Ve)	Details see form 3
37	Aux. Input 2	1.0mm <sup>2</sup>	Ground connected is active (-Ve)	
38	Aux. Input 3	1.0mm <sup>2</sup>	Ground connected is active (-Ve)	
39	Aux. Input 4	1.0mm <sup>2</sup>	Ground connected is active (-Ve)	
40	Aux. Input 5	1.0mm <sup>2</sup>	Ground connected is active (-Ve)	
41	Aux. Input COM	1.0mm <sup>2</sup>	A common terminal of input port, (-Ve) has already connected internal.	
42	RS485 COM(GND)	/	Impedance-120Ω shielding wire is recommended, its single-end earthed.	
43	RS485-	0.5mm <sup>2</sup>		

NO.	Functions	Cable Size	Remark
44	RS485+	0.5mm <sup>2</sup>	
45	CT IA	1.5mm <sup>2</sup>	Outside connected to secondary coil of current transformer (rated 5A).
46	CT IB	1.5mm <sup>2</sup>	Outside connected to secondary coil of current transformer (rated 5A).
47	CT IC	1.5mm <sup>2</sup>	Outside connected to secondary coil of current transformer (rated 5A).
48	CT ICOM	1.5mm <sup>2</sup>	See following installation instruction.
49	RS232 GSM(GND)	0.5mm <sup>2</sup>	Connected to GSM module.
50	RS232 RX	0.5mm <sup>2</sup>	
51	RS232 TX	0.5mm <sup>2</sup>	

▲ NOTE: USB ports in controller rear panel are configurable parameter ports, user can directly program controller via PC.

SmartGen

## 7 SCOPES AND DEFINITIONS OF PROGRAMMABLE PARAMETERS

### 7.1. CONTENTS AND SCOPES OF PARAMETERS

#### Form 1

No.	Items	Parameters	Defaults	Description
<b>Timer Setting</b>				
1	Start Delay	(0~3600)s	1	Time from remote start signal is active to start genset.
2	Stop Delay	(0~3600)s	1	Time from remote start signal is inactive to stop genset.
3	Preheat Delay	(0~3600)s	0	Time of pre-powering heat plug before starter is powered up.
4	Cranking Time	(3~60)s	8	Time of starter power on
5	Crank Rest Time	(3~60)s	10	The waiting time before second power up when engine start fail.
6	Safety On Delay	(0-3600)s	10	Alarms for low oil pressure, high temperature, under speed, under frequency, under voltage, charge fail are inactive.
7	Start Idle Time	(0~3600)s	0	Idle running time of genset when starting.
8	Warming Up Time	(0~3600)s	10	Warming up time between genset switch on and high speed running.
9	Cooling Time	(0~3600)s	10	Radiating time before genset stop, after it unloads.
10	Stop Idle Time	(0~3600)s	0	Idle running time when genset stop.
11	ETS Solenoid Hold	(0~3600)s	20	Stop electromagnet's power on time when genset is stopping.
12	Fail to Stop Delay	(0~3600)s	0	Time between ending of genset idle delay and stopped when "ETS time" is set as 0; Time between ending of ETS hold delay and stopped when "ETS Hold output time" is not 0.
13	After Stop Time	(0~3600)s	0	Time between genset stopped and standby.
<b>Engine Setting</b>				
1	Engine Type	(0~39)	0	Default: Conventional Engine(not

No.	Items	Parameters	Defaults	Description
				J1939)
2	Flywheel Teeth	(10~300)	118	Tooth number of the engine, for judging of starter separation conditions and inspecting of engine speed. See the installation instructions.
3	Rated Speed	(0~6000)RPM	1500	Offer standard to judge over/under/loading speed.
4	Loading Speed	(0~100)%	90	Setting value is percentage of rated speed. Controller detects when it is ready to load. It won't switch on when speed is under loading speed.
5	Loss of Speed Signal	(0~3600)s	5	Time from detecting speed is 0 to confirm the action.
6	Loss of Speed Signal Action	(0~1)	0	0:Warn; 1:Shutdown
7	Over Speed Shutdown	(0~200)%	114	Setting value is percentage of rated speed and delay value can be set.
8	Under Speed Shutdown	(0~200)%	80	
9	Over Speed Warn	(0~200)%	110	Setting value is percentage of rated speed; delay value and return value can be set.
10	Under Speed Warn	(0~200)%	86	
11	Battery Rated Voltage	(0~60.0)V	24.0	Standard for detecting of over/under voltage of battery.
12	Battery Over Volts	(0~200)%	120	Setting value is percentage of rated voltage of battery, delay value and return value can be set.
13	Battery Under Volts	(0~200)%	85	
14	Charge Alt Fail	(0~60.0)V	8.0	In normal running, when charger D+(WL) voltage under this value, charge failure alarms.
15	Start Attempts	(1~10) times	3	Max. Crank times of crank attempts. When reach this number, controller will send start failure signal.
16	Crank Disconnect	(0~6)	2	See form 5 There are 3 conditions of disconnecting starter with engine. Each condition can be used alone and simultaneously to separating the start motor and genset as soon

No.	Items	Parameters	Defaults	Description
				as possible.
17	Disconnect Generator Freq	(0~200)%	24	When generator frequency higher than the set value, starter will be disconnected. See the installation instruction.
18	Disconnect Engine Speed	(0~200)%	24	When generator speed higher than the set value, starter will be disconnected. See the installation instruction.
19	Disconnect Oil Pressure	(0~1000)kPa	Not Used	When generator oil pressure higher than the set value, starter will be disconnected. See the installation instruction.
<b>Generator Setting</b>				
1	AC System	(0~3)	0	0: 3P4W; 1: 3P3W; 2: 2P3W; 3: 1P2W.
2	Poles	(2-32)	4	Numbers of generator pole, used for calculating starter rotate speed when without speed sensor.
3	Rated Voltage	(30~30000)V	230	To offer standards for detecting of gens' over/under voltage and loading voltage. It is primary voltage when using voltage transformer.
4	Loading Voltage	(0~200)%	85	Setting value is percentage of generator rated voltage. Detect when controller ready to loading. If generator voltage under load voltage, won't enter into normally running.
5	Rated Frequency	(10.0-600.0)Hz	50.0	To offer standards for detecting of over/under/load frequency.
6	Loading Frequency	(0~200)%	85	Setting value is percentage of generator rated frequency. Detect when controller ready to loading. When generator frequency under load frequency, it won't enter into normal running.
7	Volt. Trans.(PT)	(0~1)	0	0: Disable; 1:Enable
8	Over Volt. Shutdown	(0~200)%	120	Setting value is percentage of generator rated volt. Delay value

No.	Items	Parameters	Defaults	Description
9	Under Shutdown Volt.	(0~200)%	80	can be set.
10	Over Shutdown Freq.	(0~200)%	114	Setting value is percentage of generator rated freq. Delay value can be set.
11	Under Shutdown Freq.	(0~200)%	80	
12	Over Volt. Warn	(0~200)%	110	Setting value is percentage of generator rated volt. Delay value and return value can be set.
13	Under Volt. Warn	(0~200)%	84	
14	Over Freq. Warn	(0~200)%	110	Setting value is percentage of gens rated freq. Delay value and return value can be set.
15	Under Freq. Warn	(0~200)%	84	
16	Loss of Phase	(0~1)	1	0: Disable 1: Enable
17	Phase Sequence Wrong	(0~1)	1	
<b>Generator Load Setting</b>				
1	Current Trans.	(5~6000)/5	500	The ratio of external CT
2	Full Current Rating	(5~6000)A	500	Generator's rated current, standard of load current.
3	Full kW rating	(0~6000)kW	276	Generator's rated power, standard of load power.
4	Over Current	(0~200)%	120	Setting value is percentage of generator rated volt. Delay value can be set as definite time or inverse definite minimum time
5	Over Power	(0~1)	0	0: Disable; 1: Enable
6	Reverse Power	(0~1)	0	0: Disable; 1: Enable
<b>Switch Setting</b>				
1	Close Time	(0~20.0)s	5.0	Pulse width of generator switch on. When it is 0, means output constantly.
2	Open Time	(0~20.0)s	3.0	Pulse width of generator switch off.
3	Check Time	(0~20.0)s	5.0	Time of detecting switch auxiliary contacts after transferred.
4	Check Enable Fail	(0~1)	0	0: Disable 1: Enable.
5	Open Check	(0~1)	0	
<b>Module Setting</b>				
1	Power On Mode	(0~2)	0	0: Stop mode 1: Manual mode 2: Auto mode



No.	Items	Parameters	Defaults	Description
2	Module Address	(1~254)	1	Controller's address during remote sensing.
3	Stop Bit	(0~1)	0	0: 2 stop bits; 1: 1 stop bit
4	Language	(0~2)	0	0: Simplified Chinese 1: English 2: Others
5	Password	(0~65535)	318	For entering advanced parameters setting.
<b>GSM Setting</b>				
1	GSM Enable	(0~1)	0	0: Disable; 1: Enable
2	Phone Number	Max.20 digits		0: Disable; 1: Enable Its national and area's cods must be added. e.g. China: 861366666666
<b>Scheduling And Maintenance Setting</b>				
1	Scheduled Run	(0~1)	0	0: Disable; 1: Enable
2	Scheduled Not Run	(0~1)	0	0: Disable; 1: Enable
3	Maintenance	(0~1)	0	0: Disable; 1: Enable
<b>Analog Sensors Setting</b>				
Temperature Sensor				
1	Curve Type	(0~15)	7	SGX Details see form 4.
2	Open Circuit Action	(0~2)	0	0: Warn; 1: Shutdown; 2: No action
3	High Temp. Shutdown	(0~300)°C	98	Shutdown when sensor temperature higher than this value. Detecting only after safety delay is over. The delay value can be set.
4	High Temp. Warn	(0~300)°C	95	Warn when sensor temperature higher than this value. Detecting only after safety delay is over. The delay value and return value can be set.
5	Low Temp. Warn	(0~1)	0	0: Disable; 1: Enable
Oil Pressure Sensor				
1	Curve Type	(0~15)	2	User-defined voltage curve. Details see form 4.
2	Open Circuit Action	(0~2)	0	0: Warn 1: Shutdown 2: No action
3	Low OP Shutdown	(0~1000)kPa	103	Shutdown when oil pressure lower than this value. Detecting only after safety delay is over. The delay

No.	Items	Parameters	Defaults	Description
				value can be set.
4	Low OP Warn	(0~1000)kPa	124	Warn when oil pressure lower than this value. Detecting only after safety delay is over. The delay value and return value can be set.
<b>Liquid Level Sensor</b>				
1	Curve Type	(0~15)	4	SGH See form 4
2	Open Circuit Action	(0~2)	0	0:Warn; 1:Shutdown; 2:No action
3	Low Level Warn	(0~300)%	10	Warn when level lower than this value. It is detecting all the time. The delay value and return value can be set.
<b>Flexible Sensor 1</b>				
1	Flexible Sensor 1 Setting	(0-1)	0	0: Disable 1: Enable; (can be set as temperature/pressure/liquid level sensor).
<b>Flexible Sensor 2</b>				
1	Flexible Sensor 2 Setting	(0-1)	0	0: Disable; 1: Enable; (can be set as temperature/pressure/liquid level sensor).
<b>Digital Input Ports</b>				
<b>Digital Input Port 1</b>				
1	Contents Setting	(0~50)	28	Remote Start On Load Demand. See form 3
2	Active Type	(0~1)	0	0: Closed to active 1: Open to active
<b>Digital Input Port 2</b>				
1	Contents Setting	(0~50)	26	High temperature shutdown See form 3
2	Active Type	(0~1)	0	0: Closed to active 1: Open to active
<b>Digital Input Port 3</b>				
1	Contents Setting	(0~50)	27	Low oil pressure shutdown See form 3
2	Active Type	(0~1)	0	0: Closed to active 1: Open to active
<b>Digital Input Port 4</b>				
1	Contents Setting	(0~50)	0	User defined. See form 3
2	Active Type	(0~1)	0	0: Closed to active

No.	Items	Parameters	Defaults	Description
				1: Open to active
3	Active Range	(0~3)	2	0: From safety on 1: From starting 2: Always 3:Never
4	Active Actions	(0~4)	0	0: Warn; 1: Shutdown; 2:Trip and stop 3:Trip 4: Indication
5	Active Delay	(0~20.0)s	2.0	Time from detecting active to confirm
6	Description			LCD display detailed contents when the input is active.
<b>Digital Input Port 5</b>				
1	Contents Setting	(0~50)	0	User defined. See form 3
2	Active Type	(0~1)	0	0: Closed to active 1: Open to active
3	Active Range	(0~3)	2	0: From safety on 1: From starting 2: Always 3:Never
4	Active Actions	(0~4)	1	0: Warn; 1: Shutdown; 2:Trip and stop 3:Trip 4: Indication
5	Active Delay	(0~20.0)s	2.0	Time from detecting active to confirm
6	Description			LCD display detailed contents when the input is active
<b>Digital Output Ports</b>				
<b>Digital Output Port 1</b>				
1	Contents Setting	(0~239)	1	User defined period output 1 (default output is in preheating) See Form 2
2	Active Type	(0~1)	0	0: Normally open; 1: Normally close
<b>Digital Output Port 2</b>				
1	Contents Setting	(0~239)	35	Idle control output. See Form 2
2	Active Type	(0~1)	0	0: Normally open; 1: Normally close
<b>Digital Output Port 3</b>				
1	Contents Setting	(0~239)	29	Generator closed output. See form 2
2	Active Type	(0~1)	0	0: Normally open; 1: Normally close
<b>Digital Output Port 4</b>				
1	Contents Setting	(0~239)	31	Reversed. See form 2
2	Active Type	(0~1)	0	0: Normally open; 1: Normally close
<b>Digital Output Port 5</b>				
1	Contents Setting	(0~239)	38	ETS solenoid hold. See form 2
2	Active Type	(0~1)	0	0: Normally open; 1: Normally close

No.	Items	Parameters	Defaults	Description
Digital Output Port 6				
1	Contents Setting	(0~239)	48	Common alarm. See form 2
2	Active Type	(0~1)	0	0:Normally open; 1:Normally close
GOV Setting				
1	Output Type	(0~1)	0	0: Continuous; 1: Step
2	Load Type	(0~3)	0	0: AC Power; 1: AC Current; 2: DC Power; 3: DC Current
3	Output Curve			GOV output different voltage when different power or current are set.
4	High Speed Enable	(0~1)	0	0: Disable; 1: Enable
5	GOV	(0~10.0)V	3.0	GOV output voltage when "GOV High Speed" is enabled.
6	GOV Delay	(0~3600)s	0	Set "high speed" output delay value.
7	DC Input Enable	(0~1)	0	0: Disable; 1: Enable
8	DC Sensor Curve			X means output voltage value while y means the corresponding current value.
9	Power Ratio	(1~10)	1	Active power is multiplier ratio of sample power.

## 7.2. PROGRAMMABLE OUTPUT PORTS

### Form 2

No.	Type	Description
0	Not Used	
1	Custom Period 1	Details of function description please see the following.
2	Custom Period 2	
3	Custom Period 3	
4	Custom Period 4	
5	Custom Period 5	
6	Custom Period 6	
7	Custom Combined 1	
8	Custom Combined 2	
9	Custom Combined 3	
10	Custom Combined 4	
11	Custom Combined 5	
12	Custom Combined 6	
13~16	Reserved	
17	Air Flap Control	Action when over speed shutdown and emergence stop. It also can close the air inflow to stop the engine as soon as possible.
18	Audible Alarm	Action when warning, shutdown, trips. Can be connected annunciator externally. When "alarm mute" configurable input port is active, it can remove the alarm.
19	Louver Control	Action when genset start and disconnect when genset stopped completely.
20	Fuel Pump Control	It is controlled by limited threshold of fuel pump.
21	Heater Control	It is controlled by limited threshold of heater.
22	Cooler Control	It is controlled by limited threshold of cooler.
23	Oil Pre-supply Output	Action from "crank on" to "safety on".
24	Generator Excite	Output in start period. If there is no generator frequency during hi-speed running, then output for 2 seconds again.
25	Pre-Lubricate	Actions in period of pre-heating to safety run.
26	Remote Control Output	This port is controlled by communication (PC).
27	GSM Power Supply	Power for GSM module (GSM module is reset when GSM communication failed).
28	Reserved	
29	Close Gen Output	Control generator to take load.
30	Open Breaker Output	Control generator to off load.
31	Reserved	
32	Reserved	

33	Start Relay	
34	Fuel Relay	Action when genset start and disconnect when genset stop completely.
35	Idle Control	Used for engine which has idles. Close before starting and open in warming up delay; Close during stopping idle process and open when stop is completed.
36	Speed Raise Relay	Action in warming up delay.
37	Speed Drop Relay	Action between the period from “stop idle” to “failed to stop”.
38	Energize to Stop	Used for engines with ETS electromagnet. Close when stop idle is over and open when pre-set “ETS delay” is over.
39	Speed Drop Pulse	Active 0.1s when controller enters into stop idle, used for control part of ECU dropping to idle speed.
40	Reserved	
41	Reserved	
42	Speed Raise Pulse	Active 0.1s when controller enters into warming up delay; used for control part of ECU raising to normal speed.
43	Crank Success	Close when detects a successful start signal.
44	Generator OK	Action when generator is normal.
45	Generator Load Available	Action in period of generator normal running to high-speed cooling.
46	Reserved	
47	Reserved	
48	Common Alarm	Action when genset common warning, common shutdown or common trips alarm occurs.
49	Common Trip and Stop	Action when common trip and stop alarm occurs.
50	Common Shutdown	Action when common shutdown alarm occurs.
51	Common Trip	Action when common trips alarm occurs.
52	Common Warn	Action when common warning alarm occurs.
53	Reserved	
54	Battery Over Voltage	Action when battery’s over voltage warning alarm occurs.
55	Battery Under Voltage	Action when battery’s low voltage warning alarm occurs.
56	Charge Alternator Failure	Action when charge failure warning alarm occurs.
57~68	Reserved	
69	Digital Input 1 Active	Action when input port 1 is active
70	Digital Input 2 Active	Action when input port 2 is active

71	Digital Input 3 Active	Action when input port 3 is active
72	Digital Input 4 Active	Action when input port 4 is active
73	Digital Input 5 Active	Action when input port 5 is active
74~98	Reserved	
99	Emergency Stop	Action when emergency stop alarm.
100	Fail To Start	Action when start failure alarm.
101	Fail To Stop	Action when stop failure alarm.
102	Under Speed Warn	Action when under speed alarm.
103	Under Speed Shutdown	Action when under speed shutdown alarm.
104	Over Speed Warn	Action when over speed warns.
105	Over Speed Shutdown	Action when over speed shutdown alarm.
106~108	Reserved	
109	Gen Over Freq. Warn	Action when generator over frequency warning occurs.
110	Gen Over Freq. Shut	Action when generator over frequency shutdown alarm occurs.
111	Gen Over Volt Warn	Action when generator over voltage warning occurs.
112	Gen Over Volt Shut	Action when generator over voltage shutdown occurs.
113	Gen Under Freq. Warn	Action when generator low frequency warning occurs.
114	Gen Under Freq. Shut	Action when generator low frequency shutdown occurs.
115	Gen Under Volt. Warn	Action when generator low voltage warning occurs.
116	Gen Under Volt. Shut	Action when generator low voltage shutdown occurs.
117	Gen Loss of Phase	Action when generator loss phase.
118	Gen Phase Sequence Wrong	Action when generator reverse phase.
119	Reserved	
120	Over Power	Action when controller detects generator over power occurs.
121	Reserved	
122	Generator Reverse Power	Action when controller detects generator have reverse power.
123	Over Current	Action when generator over current occurs.
124~138	Reserved	
139	High Temp Warn	Action when hi-temperature warning occurs.
140	Low Temp Warn	Action when low temperature warning occurs.
141	High Temp Shutdown	Action when high-temperature shutdown alarm occurs.
142	Reserved	

143	Low OP Warn	Action when low oil pressure warning occurs.
144	Low OP Shutdown	Action when low oil pressure shutdown alarm occurs.
145	Oil Pressure Open Circuit	Action when oil pressure sensor is open circuit.
146	Reserved	
147	Low Fuel Level	Action when low fuel level alarm occurs.
148	Reserved	
149	Reserved	
150	Config. Sensor 1 High Warn	
151	Config. Sensor 1 Low Warn	
152	Config. Sensor 1 High Shut	
153	Config. Sensor 1 Low Shut	
154	Config. Sensor 2 High Warn	
155	Config. Sensor 2 Low Warn	
156	Config. Sensor 2 High Shut	
157	Config. Sensor 2 Low Shut	
158~229	Reserved	
230	Stop Mode	Action in stop mode.
231	Manual Mode	Action in Manual mode.
232	Reserved	
233	Auto Mode	Action in Auto mode.
234	Generator Load	
235~239	Reserved	

### 7.2.1 DEFINED PERIOD OUTPUT

Defined Period output is composed by 2 parts, period output S1 and condition output S2.



While S1 and S2 are **TRUE** synchronously, OUTPUT;

While S1 or S2 is **FALSE**, NOT OUTPUT.

Period output S1, can set generator's one or more period output freely, can set the delayed time and output time after enter into period.

Condition output S2, can be set as any item is given in the section entitled *Programmable Output Ports* elsewhere in this manual.

**▲NOTE:** when delay time and output time both are 0 in period output S1, means it is **TRUE** in this period.

Example:



Output period: start

Delay time: 2s

Output time: 3s

Condition output contents: output port 1 is active

Close when condition output active/inactive: close when active (disconnect when inactive);

Output port 1 active: after enter “starting time” and delay 2s, this defined period output is outputting, after 3s, stop outputting;

Output port 1 inactive: defined output period is not outputting.

### 7.2.2 DEFINED COMBINATION OUTPUT

Defined combination output is composed by 3 parts, condition output S1 or S2 and condition output S3.

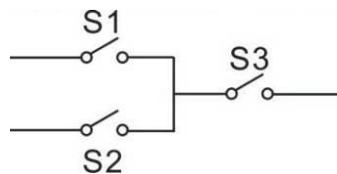

S1 or S2 is **TRUE**, while S3 is **TRUE**, Defined combination output is outputting;

S1 and S2 are **FALSE**, or S3 is **FALSE**, Defined combination output is not outputting.

▲**NOTE:** S1, S2, S3 can be set as any item except for “defined combination output” which is given in the section entitled *Programmable Output Ports* elsewhere in this manual.

▲**NOTE:** 3 parts of defined combination output (S1, S2, S3) couldn't include or recursively include themselves.

Example,

Contents of condition output S1: output port 1 is active;

Close when condition output S1 is active /inactive: close when active (disconnect when inactive);

Contents of condition output S2: output port 2 is active;

Close when condition output S2 is active /inactive: close when active (disconnect when inactive);

Contents of condition output S3: output port 3 is active;









Close when condition output S3 is active /inactive: close when active (disconnect when inactive);

When input port 1 active or input port 2 active, if input port 3 is active, Defined Combination Output is outputting; If input port 3 inactive, Defined Combination Output is not outputting;

When input port 1 inactive and moreover, input port 2 inactive, whatever input port 3 is active or not, Defined Combination Output is not outputting.

## 7.3 PROGRAMMABLE INPUT PORTS (ALL ACTIVE WHEN CONNECT TO GRAND (B-))

### Form 3

No.	Type	Description
0	Users Configured	Including following functions, Indication: indicate only, not warning or shutdown. Warning: warn only, not shutdown. Shutdown: alarm and shutdown immediately Trip and stop: alarm, generator unloads and shutdown after hi-speed cooling Trip: alarm, generator unloads but not shutdown. Never: input inactive. Always: input is active all the time. From crank: detecting from generator start. From safety on: detecting after safety on delay.
1	Reserved	
2	Alarm Mute	Can prohibit "Audible Alarm" output when input is active.
3	Reset Alarm	Can reset shutdown alarm and trip alarm when input is active.
4	60Hz Active	Use for CANBUS engine and it is 60Hz when input is active.
5	Lamp Test	All LED indicators are illuminating when input is active.
6	Panel Lock	All buttons in panel is inactive except    and there is  in the right of first row in LCD when input is active.
7	High Speed Mode	GOV output setting voltage when the input is active.
8	Idle Control Mode	Under voltage/frequency/speed protection is inactive.
9	Inhibit Auto Stop	In Auto mode, during generator normal running, when input is active, prohibit generator shutdown automatically.
10	Inhibit Auto Start	In Auto mode, prohibit generator start automatically when input is active.
11	Inhibit Scheduled	In Auto mode, prohibit fixed timing start genset when input is active.
12	Reserved	
13	Aux Gen Closed	Connect generator loading switch's auxiliary point.
14	Inhibit Gen Load	Prohibit genset switch on when input is active.
15	Reserved	
16	Reserved	
17	Auto Mode Lock	When input is active, controller enters into Auto Mode; all the keys except     are inactive and there is  in the right of first row in LCD.
18	Auto Mode Invalid	When input is active, controller won't work under Auto

		Mode.  key and simulate auto key input does not work.
19	Reserved	
20	Reserved	
21	Inhibit Alarm Stop	All shutdown alarms are prohibited except emergency stop.(i.e. battle mode or override mode)
22	Aux Instrument Mode	All outputs are prohibited in this mode.
23	Reserved	
24	Reset Maintenance	Controller will set maintenance time and date as default when input is active.
25	Reserved	
26	Aux. High Temp	Connect to sensor digital input.
27	Aux. Low OP	Connect to sensor digital input.
28	Remote Start (On Load)	In Auto mode, when input is active, can start genset automatically and with load when genset is normal running; when input is inactive, can stop genset automatically.
29	Remote Start (Off Load)	In Auto mode, when input is active, can start genset automatically and off load when genset is normal running; when input is inactive, can stop genset automatically.
30	Aux. Manual Start	In Manual mode, when input is active, can start genset automatically; when input is inactive, can stop genset automatically.
31	Reserved	
32	Reserved	
33	Simulate Stop key	An external button; can be connected to simulate panel button.
34	Simulate Manual key	
35	Reserved	
36	Simulate Auto key	An external button; can be connected to simulate panel button.
37	Simulate Start key	
38	Simulate Gen Load key	
39~46	Reserved	
47	Alternative Config1	Alternative configuration is active when the input is active. Users can set different parameters to make it easy to select current configuration via input port.
48	Alternative Config2	
49	Alternative Config3	
50	Reserved	

## 7.4. SELECTION OF SENSORS

### Form4

No.	Items	Description	Remark
1	Temperature Sensor	0 Not used 1 Custom Res Curve 2 Custom 4-20mA curve 3 VDO 4 CURTIS 5 VOLVO-EC 6 DATCON 7 SGX 8 SGD 9 SGH 10 PT100 11~15 Reserved	Defined resistance's range is (0~6)KΩ, default is SGX sensor.
2	Pressure Sensor	0 Not used 1 Custom Res Curve 2 Custom Voltage Curve 3 VDO 10Bar 4 CURTIS 5 VOLVO-EC 6 DATCON 10Bar 7 SGX 8 SGD 9 SGH 10~15 Reserved	Defined resistance's range is (0~6)KΩ, default is SGX sensor.
3	Fuel Level Sensor	0 Not used 1 Custom Res Curve 2 Custom 4-20mA Curve 3 SGD 4 SGH 5~15 Reserved	Defined resistance's range is (0~6)KΩ, default is SGH sensor.

 **NOTE:** User should make special declare when order controller if your genset equip with 4~20mA sensor.

## 7.5 CONDITIONS OF CRANK DINSCONNECT SELECTION

No.	Setting description
0	Generator Frequency
1	Engine Speed
2	Engine Speed + Generator Frequency
3	Oil pressure
4	Oil pressure + Generator Frequency
5	Oil pressure + Engine Speed
6	Oil pressure + Engine Speed + Generator Frequency

### NOTE:

- 1) There are 3 conditions to make starter disconnected with engine, that is, engine speed, generator frequency and oil pressure. They all can be used separately. We recommend that oil pressure should be using with speed sensor and generator frequency together, in order to make the starter separate with engine as soon as possible and can check start exactly.
- 2) Speed sensor is the magnetic equipment which be installed in starter for detecting flywheel teeth.
- 3) When set as engine speed, must ensure that the number of flywheel teeth is as same as setting, otherwise, “over speed stop” or “under speed stop” may be caused.
- 4) If genset without speed sensor, please don't select corresponding items which include *engine speed*, otherwise, “start fail” or “loss of speed signal” maybe caused.
- 5) If genset without oil pressure sensor, please don't select corresponding items which include *oil pressure*.
- 6) If not select generator frequency in crank disconnect setting, controller will not collect and display the relative power quantity (can be used in water pump set); if not select engine speed in crank disconnect setting, the rotating speed displayed on LCD is calculated by generator frequency and number of poles.

## 8 PARAMETERS SETTING

**▲CAUTION:** Please change the controller parameters when generator is in standby mode only (e. g. Crank disconnect conditions selection, configurable input, configurable output, various delay), otherwise, shutdown alarm or other abnormal conditions may occur.

**▲NOTE:** Maximum set value must greater than minimum set value in case that the condition of too high as well as too low may occur.

**▲NOTE:** When setting the warning alarm, please set the correct return value; otherwise, maybe abnormal alarm occurs. When setting the maximum value, the return value must less than set value; When setting the minimum value, the return value must greater than set value.

**▲NOTE:** Please set the generator frequency value as low as possible when cranking, in order to make the starter separate with engine as soon as possible.

**▲NOTE:** Configurable input ports could not be set as same items; otherwise, abnormal functions occur. However, the configurable output ports can be set as same items.

## 9 SENSORS SETTING

- 1) When reselect sensors, the sensor curve will be transferred into the standard value. For example, if default temperature sensor is SGX (120°C resistor type), its sensor curve is SGX (120°C resistor type); if select the SGD (120°C resistor type), the temperature sensor curve is SGD curve.
- 2) When there is difference between standard sensor curves and using one, user can adjust it in “curve type”.
- 3) When input the sensor curve, X value (resistor) must be input from small to large, otherwise, mistake occurs.
- 4) If select sensor type as “None”, sensor curve is not working.
- 5) If corresponding sensor has alarm switch only, user must set this sensor as “None”, otherwise, shutdown or warning alarm occurs.
- 6) The headmost or backmost values in the vertical coordinates can be set as the same one, as shown below,

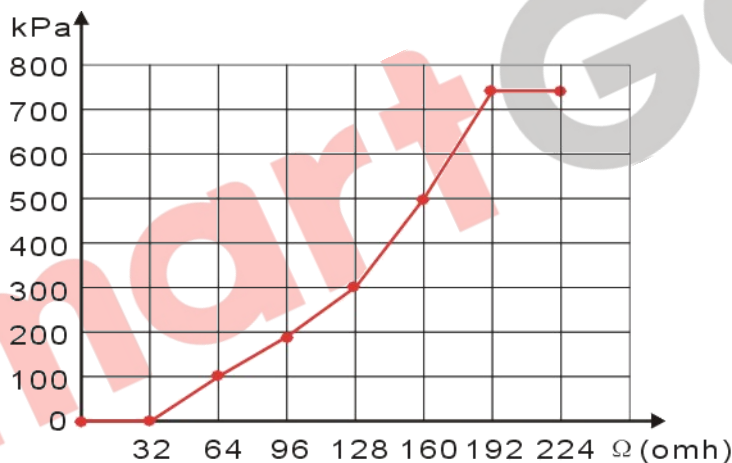

**Normal Pressure Unit Conversion Form**

	pa	kgf/cm <sup>2</sup>	bar	psi
1Pa	1	1.02x10 <sup>-5</sup>	1x10 <sup>-5</sup>	1.45x10 <sup>-4</sup>
1kgf/cm <sup>2</sup>	9.8x10 <sup>4</sup>	1	0.98	14.2
1bar	1x10 <sup>5</sup>	1.02	1	14.5
1psi	6.89x10 <sup>3</sup>	7.03x10 <sup>-2</sup>	6.89x10 <sup>-2</sup>	1

## 10 COMMISSIONING

Please make the under procedures checking before commissioning,

1. Ensure all the connections are correct and wires diameter is suitable.
2. Ensure that the controller DC power has fuse, controller's positive and negative connected to start battery are correct.
3. Emergence stop must be connected with positive of start battery via scram button's normal close point and fuse.
4. Take proper action to prevent engine to crank disconnect (e. g. Remove the connection wire of fuel valve). If checking is OK, make the start battery power on; choose manual mode and controller will executive routine.
5. Set controller under manual mode, press "start" button, genset will start. After the setting times as setting, controller will send signal of Start Fail; then press "stop" to reset controller.
6. Recover the action of stop engine start (e. g. Connect wire of fuel valve), press start button again, genset will start. If everything goes well, genset will normal run after idle running (if idle run be set). During this time, please watch for engine's running situations and AC generator's voltage and frequency. If abnormal, stop genset running and check all wires connection according to this manual.
7. Select the **AUTO** mode from controller's panel and enable remote start(on load) active. After start delay, gen-set will enter normal running, and then controller send signal to making generator switch on, and control the ATS as generator load. If not like this, please check ATS' wires connection of control part according to this manual.
8. Make remote start (on load) deactivated. After stop delay, "Open Breaker" signal will be initiated make generator switch off and control the ATS. After the "cooling delay" has expired, controller enters standby mode and activates until receiving remote start signal.
9. If there is any other question, please contact Smartgen's service.



## 11 TYPICAL APPLICATION

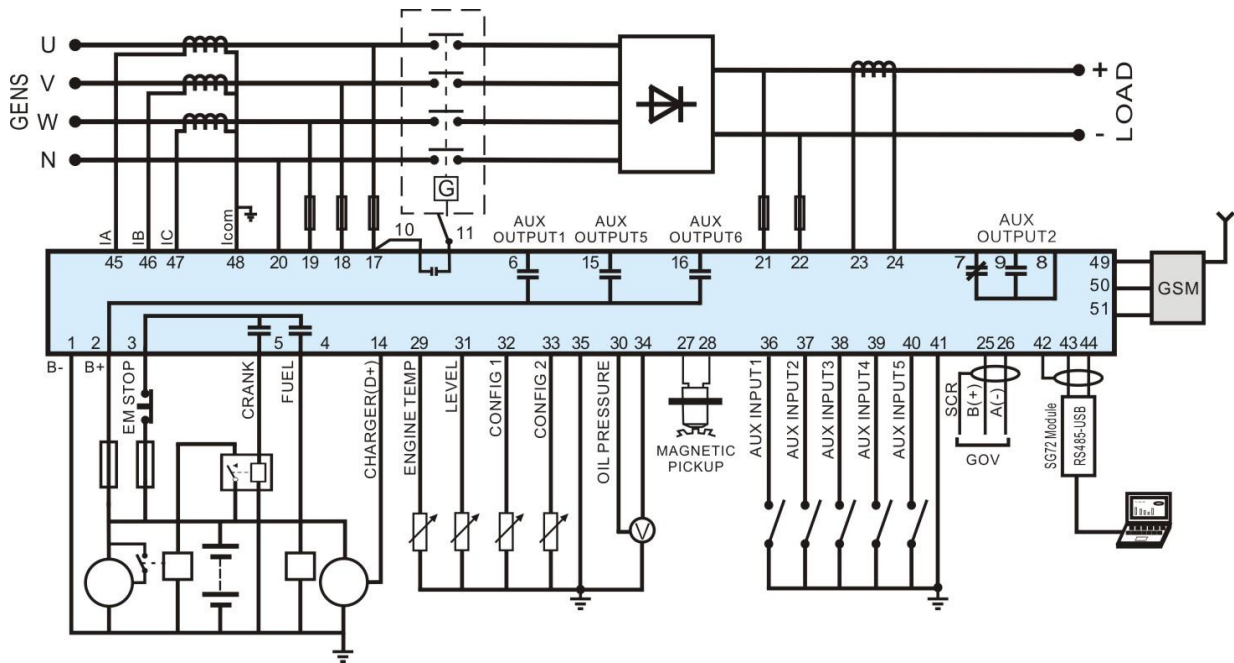

SmartGen

## 12 INSTALLATION

Controller is panel built-in design; it is fixed by clips when installed. The controller's overall dimensions and cutout dimensions for panel, please refer to as following,

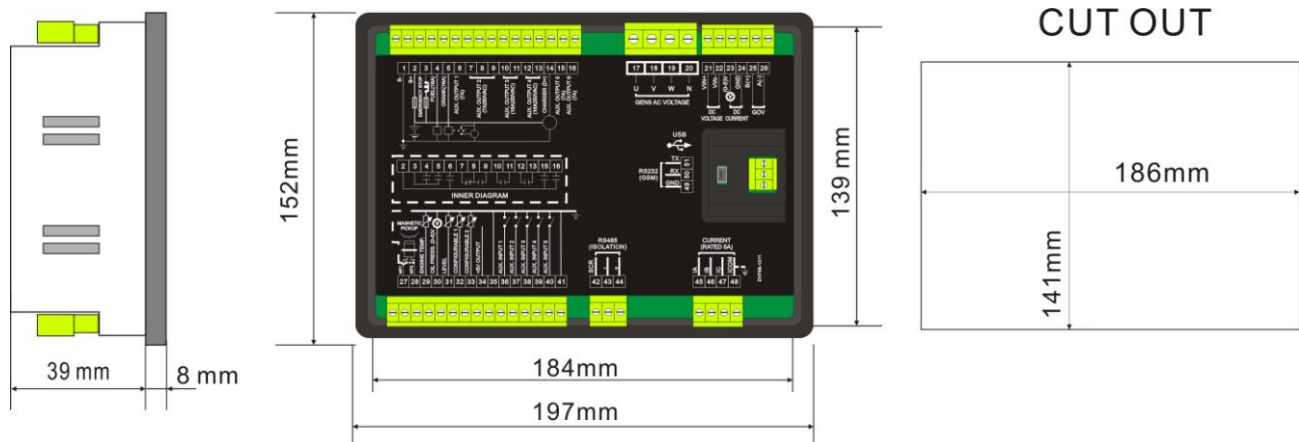

### 1) Battery Voltage Input

**NOTE:** HGM7110VS controller can suit for widely range of battery voltage DC(8~35)V. Negative of battery must be connected with the shell of starter. The wire's diameter connect controller and battery must be over  $2.5\text{mm}^2$ . If floating charger configured, please firstly connect output wires of charger to battery's positive and negative directly, then, connect wires from battery's positive and negative to controller's corresponding ports in order to prevent the charger interfere with the normal operation of the controller.

### 2) Speed Sensor Input

**NOTE:** Speed sensor is the magnetic equipment which be installed in starter and for detecting flywheel teeth. Its connection wires to controller should apply for 2 cores shielding line. The shielding layer should connect to No. 28 terminal in controller while another side is hanging in air. The else two signal wires are connected to No.27 and No.28 terminals in controller. The output voltage of speed sensor should be within AC (1~24)V (effective value) during the full speed. AC12V is recommended (in rated speed). When install the speed sensor, spun the sensor until only the pointed end is protruding from the flywheel, then, withdraw 1/3 lap, and lock the nuts of the sensor at last.

### 3) Output And Expand Relays

**CAUTION:** All outputs of controller are relay contact output. If need to expand the relays, please add freewheel diode to both ends of expand relay's coils (when relay coils has DC current) or, increase resistance-capacitance return circuit (when relay coils has AC current), in order to prevent disturbance to controller or others equipment.

### 4) AC Input

Current transformer must be connected externally and the current transformer's secondary side current must be 5A. At the same time, the phases of current transformer and input voltage must be correct. Otherwise, the collected current and active power maybe not correct.

 **NOTE:** ICOM port must be connected to negative pole of battery.

 **WARNING!** When there is load current, transformer's secondary side prohibit open circuit.

#### 5) **Withstand Voltage Test**

 **CAUTION!** When controller had been installed in control panel, if need the high voltage test, please disconnect controller's all terminal connections, in order to prevent high voltage into controller and damage it.

SmartGen

## 13 GSM SHORT MESSAGE ALARM AND REMOTE CONTROL

### 13.1 GSM SHORT MESSAGE ALARM

When controller detects alarm, it will send short message to phone automatically.

**NOTE:** All alarms about shutdown, trip and stop and trip will be sent to the pre-set phone. Warnings are sent to the phone according to the pre-set.

### 13.2 GSM SHORT MESSAGE REMOTE CONTROL

Users send order message to GSM module, then controller will make actions according to this SMS order and pass back corresponding operations information. Controllers only execute the orders by pre-set. Detail orders as following:

No.	SMS Orders	Pass back Information	Description
1	SMS GENSET	GENSET ALARM	When genset is stopping alarm
		SYSTEM IN STOP MODE GENSET AT REST	At rest status in stop mode
		SYSTEM IN MANUAL MODE GENSET AT REST	At rest status in manual mode
		SYSTEM IN AUTO MODE GENSET AT REST	At rest status in Auto mode
		SYSTEM IN STOP MODE GENSET IS RUNNING	Running status in stop mode
		SYSTEM IN MANUAL MODE GENSET IS RUNNING	Running status in manual mode
		SYSTEM IN AUTO MODE GENSET AT RUNNING	Running status in Auto mode
		GENSET ALARM	Generator is shutdown alarm or trip alarm
2	SMS START	STOP MODE NOT START	Cannot start in stop mode
		SMS START OK	Start in manual mode
		AUTO MODE NOT	Cannot start in auto

		START	mode
3	SMS STOP MODE	SMS STOP OK	Set as stop mode
4	SMS MANUAL MODE	SMS MANUAL MODE OK	Set as manual mode
5	SMS AUTO MODE	SMS AUTO MODE OK	Set as auto mode
6	SMS DETAIL	Pass back information can be set via controller software.	Gets details information of genset.

**NOTE:** Its national and area's cods must be added. e.g. China: 8613666666666.

**NOTE:** When sending orders, users need to follow SMS orders in above form and all the letters must be capital.

**NOTE:** Pass back information from SMS DETAIL including: working mode, generator voltage, load current, generator frequency, active power, apparent power, power factor, battery voltage, D+ voltage, water temperature, oil pressure, oil level, engine speed, total running time, genset status, and alarm status.

## 14 FAULT FINDING

Symptoms	Possible Solutions
Controller no response with power.	Check starting batteries; Check controller connection wirings; Check DC fuse.
Genset shutdown	Check the water/cylinder temperature is too high or not; Check the genset AC voltage; Check DC fuse.
Controller emergency stop	Check emergence stop button is correct or not; Check whether the starting battery positive is connected with the emergency stop input; Check whether the circuit is open.
Low oil pressure alarm after crank disconnect	Check the oil pressure sensor and its connections.
High water temp. alarm after crank disconnect	Check the temperature sensor and its connections.
Shutdown Alarm in running	Check related switch and its connections according to the information on LCD; Check programmable inputs.
Crank not disconnect	Check fuel oil circuit and its connections; Check starting batteries; Check speed sensor and its connections; Refer to engine manual.
Starter no response	Check starter connections; Check starting batteries.
Genset running while ATS not transfer	Check ATS; Check the connections between ATS and controllers.
RS485 communication is abnormal	Check connections; Check setting of COM port is correct or not; Check RS485's connections of A and B is reverse connect or not; Check RS485 transfer model whether damage or not; Check communication port of PC whether damage.